



SPEETEC 1D

CAPTURES MOTION.
WITHOUT CONTACT.

Non-contact motion sensors

SICK
Sensor Intelligence.

CAPTURES MOTION. WITHOUT CONTACT.



Product description

The wear-and-tear and maintenance-free SPEETEC 1D laser surface motion sensor detects the movements of object surfaces without contacting them. This detection requires no scale or measuring elements. The laser Doppler effect based technology enables the SPEETEC 1D to measure the speed, length, movement direction and position of objects on almost any surfaces. The

non-contact measurement method used by the sensor makes it particularly suitable for applications with soft or sensitive surfaces that would be damaged by tactile measurement. The SPEETEC 1D is also ideal for encoder applications with fast and dynamic processes that are unsuitable for encoders. The sensor can be monitored and logic functions configured via an interface.

At a glance

- Non-contact measurement of speed, length and position without measuring elements
- Compatible with many materials, colors and surfaces
- Very high measurement accuracy and repeatability
- Laser class 1
- Rugged design, compact dimensions, low weight
- TTL or HTL interface
- Diagnostics and parameterization function.

Your benefits

- Opens up new possibilities for measuring sensitive, soft or smooth objects
- Optical sensors avoid damage to, and contamination of the surfaces being measured and ensure a high product quality
- Slip-free measurement increases the measurement accuracy thereby optimizing productivity and process quality
- Thanks to the use of class 1 lasers, no expensive laser protection measures and no specially trained personnel are required
- High measurement accuracy, including in start-stop operation and at short measurement lengths
- Configuration interface allows application and sensor diagnostics as well as parameterization
- Easy to retrofit, wear and maintenance free



Additional information

Fields of application	3
Detailed technical data	3-4
Type code	5
Ordering information	7
Dimensional drawings	8
PIN assignment	8-9
Attachment specifications	10-11
Interfaces	12
Accessories	13-14

→ www.sick.com/SPEETEC_1D

For more information, simply enter the link or scan the QR code and get direct access to technical data, CAD design models, operating instructions, software, application examples, and much more.



Fields of application

- Consumer goods industry, e.g., packaging, digital printing
- Mechanical engineering, e.g., extrusion, metal processing, surface treatment
- Tire manufacturing, e.g., tire building
- Construction materials industry, e.g., insulating materials, dry construction
- Quality control
- Cutting processes

Detailed technical data

Safety-related parameters

MTTFd: mean time to dangerous failure	33 years ¹⁾
--	------------------------

¹⁾ This product is a standard product and does not constitute a safety component as defined in the Machinery Directive. Calculation based on nominal load of components, average ambient temperature 40°C, frequency of use 8760 h/a. All electronic failures are considered hazardous. For more information, see document no. 8015532.

Performance

Nominal measuring distance	50 mm
Static mounting tolerance	Ca. ± 5 mm ¹⁾
Direction of movement	1D, x-direction
Movement detection	Bidirectional
Measuring increment (resolution in µm/pulse)	4 - 2,000 (At 90° electrical)
Speed measuring range	> 0 m/s ... 10 m/s ²⁾
Permissible acceleration	≤ 30 m/s ²
Accuracy	
Measurement accuracy	0.1 % ³⁾
Repeatability	0.05 % ⁴⁾
Internal sampling rate	330 µs
Latency period	2.9 ms

¹⁾ Mounting the device closer than the specified measuring distance will not affect the accuracy of the measurement for suitable materials. Operation outside of the tolerance is possible with restrictions.

²⁾ No continuous operation < 0.1 m/s recommended.

³⁾ Error limit for systematic measurement deviation in accordance with DIN 1319-1:1995. Valid between 0.2 m/s ... 10 m/s.

⁴⁾ Maximum permissible measurement deviation in accordance with DIN 1319-1:1995 under constant conditions. Valid between 0.2 m/s ... 10 m/s, averaged over 0.25 m measuring length.

System

Light source	2 continuous beam lasers ¹⁾
Shaft length	850 nm
Laser class	1 (IEC 60825-1:2014)
Type of light	Invisible infrared light
Typ. measurement field size (distance)	2 mm x 3 mm (at 50 mm) 8 mm x 3 mm (at 45 mm) 8 mm x 3 mm (at 55 mm)
Laser power (per laser)	0.78 mW ²⁾

¹⁾ L10 ≥ 32,500 h (not temperature-dependent). The lasers are always on when the sensor is supplied with voltage. To increase the service life of the sensor, we recommend completely disconnecting the sensor from the voltage supply when it is not needed. No warranty claims relating to the reaching of the service life of the laser will be accepted.

²⁾ The device must not be operated if the screen is damaged or missing.

Mechanical data

Dimensions	140 mm x 95 mm x 32.5 mm (without plug)
Weight	400 g

¹⁾ Exceeding these values will result in lower accuracy (see: Permissible deviations from nominal alignment).

Material	Housing	Aluminum
	Screen	PMMA
	Plug insert	PA66, copper-zinc alloy (CuZn)
Permissible angle	Permissible pitch angle	$\leq \pm 1.5^\circ$ ¹⁾
	Permissible yaw angle	$\leq \pm 1.5^\circ$ ¹⁾
	Permissible roll angle	$\leq \pm 10^\circ$ ¹⁾

¹⁾ Exceeding these values will result in lower accuracy (see: Permissible deviations from nominal alignment).

Electrical data

Supply voltage	12 V ... 30 V
Communication interface	TTL / RS-422 ¹⁾ HTL / Push pull ¹⁾
Output frequency	≤ 625 kHz
Connection type	Male connector, M12, 8-pin, A-coded
Parameterization and diagnostic interface	Type-dependent, only for parameterizable variants (see type code)
Digital input	Type-dependent, only for parameterizable variants (see type code)
Digital output	Type-dependent, only for parameterizable variants (see type code)
Power consumption	< 8 W
Load current	≤ 30 mA, per channel
Reverse polarity protection	✓
Protection class	III according to DIN EN 61140
Short-circuit resistant outputs	
TTL / RS-422	✓ ²⁾
HTL / Push pull	✓ ³⁾
Digital input	✓ ³⁾
Digital output	✓ ³⁾
Initialization time	Max. 3 s ⁴⁾

¹⁾ With 4-channels unless noted.

²⁾ Short-circuit to another channel or GND permissible for a maximum of 30 s. No protection in the case of a short-circuit channel of U_s.

²⁾ Short-circuit to another channel, U_s or GND for max. 30 s.

³⁾ Digital output DO can have an undefined state during this time.

Ambient data

EMC	EN 61000-6-2, EN 61000-6-3
Enclosure rating	IP65 (EN 60529) ¹⁾ IP67 (EN 60529) ¹⁾
Permissible relative humidity	70 % ²⁾
Temperature	
Operating temperature range	0 °C ... +45 °C ³⁾
Storage temperature range	-32 °C ... +60 °C, without package
Resistance	
Resistance to shocks	30 g, 6 ms (EN 60068-2-27)
Resistance to vibration	20 g, 10 Hz ... 2,000 Hz (EN 60068-2-6)

¹⁾ For suitable mating connector and correct mounting of the mating connector.

²⁾ Condensation on laser modules and screen not permitted.

³⁾ If the permissible temperature range is exceeded, the sensor switches off the laser to protect it against damage. No signal is outputted in this case. The variant with parameterization and diagnostic functions offers the option of monitoring the internal temperature and therefore reserves up until the point of switching off.

Type code

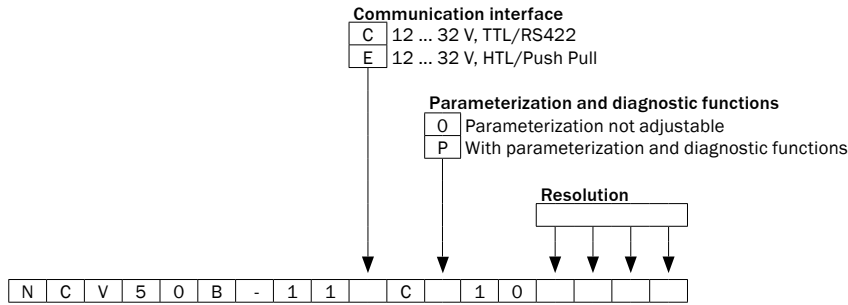

Preferred resolutions

Designation in the type code	Resolution/Measurement step(90° electrical)	Resolution/Measurement step (360° electrical)
0004	4 µm	16 µm
0020	20 µm	80 µm
0100	100 µm	400 µm
0200	200 µm	800 µm
1000	1000 µm	4000 µm

Other resolutions are available on request - please contact us. With the parameterizable version you can choose from all technically possible resolutions yourself.

Permissible lengths of cable

Speed (m/s)	Resolution/Measurement step(90° electrical)	Frequency	Permissible lengths of cable for TTL	Permissible lengths of cable for HTL
0.1	4 µm	6.25 kHz	350 m	100 m
1	4 µm	62.5 kHz	350 m	20 m
4	4 µm	250 kHz	350 m	5 m
5	4 µm	312.5 kHz	250 m	2 m
10	4 µm	625 kHz	250 m	-

For four-fold evaluation, differential, the frequency is calculated as follows:

$$\text{Frequency} = (\text{speed}/\text{resolution}) / 4$$

Example:

$$(5.0 \text{ m/s} / 4 \text{ µm}) / 4 = 312.5 \text{ kHz}$$

Functions of the parameterization and diagnostics interface

Notes

The PGT-14 programming tool is required to use the parameterization and diagnostics function, see Accessories.

To use the logic functions, the YM2A28-C20S01MYAAX signal distribution cable and a suitable trigger sensor with PNP switching output and M8 connector, 4-pin are required.

Variants with the parameterization and diagnostics interface offer the following functions:

Parameterization

- of the electrical interface TTL or HTL
- of the measuring step length in steps of 4 µm
- of the movement direction forward or backward
- of the digital inputs and outputs functionality
 - logic function “Deactivate incremental signal”
 - logic function “Digital trigger output active after certain length”

Diagnosis

- of the operating hours counter
- of the internal sensor temperature
- of the current speed value
- of the current signal-to-noise ratio
- of the digital input and output state

Note: The interface is not designed as a permanent connection. The line of the programming tool must not be extended.

Ordering information

- **Without parameterization and diagnostic interface**
- **Measuring distance:** 50 mm
- **Supply voltage:** 12 V ... 30 V

Part no.	Type	Resolution/Measurement step (90° electrical)	Output level
1106854	NCV50B-11CC0100004	4 µm	TTL
1106855	NCV50B-11CC0100100	100 µm	TTL
1106856	NCV50B-11EC0100004	4 µm	HTL
1106857	NCV50B-11EC0100100	100 µm	HTL
1115004	NCV50B-11EC0101000	1,000	HTL

- **With parameterization and diagnostic interface**
- **Measuring distance:** 50 mm
- **Supply voltage:** 12 V ... 30 V

Part no.	Type	Resolution / Measurement step (90° electrical)	Output level
1121431	NCV50B-11CCP100100	100 µm	TTL

Dimensional drawings (Dimensions in mm (inch))

SPEETEC 1D

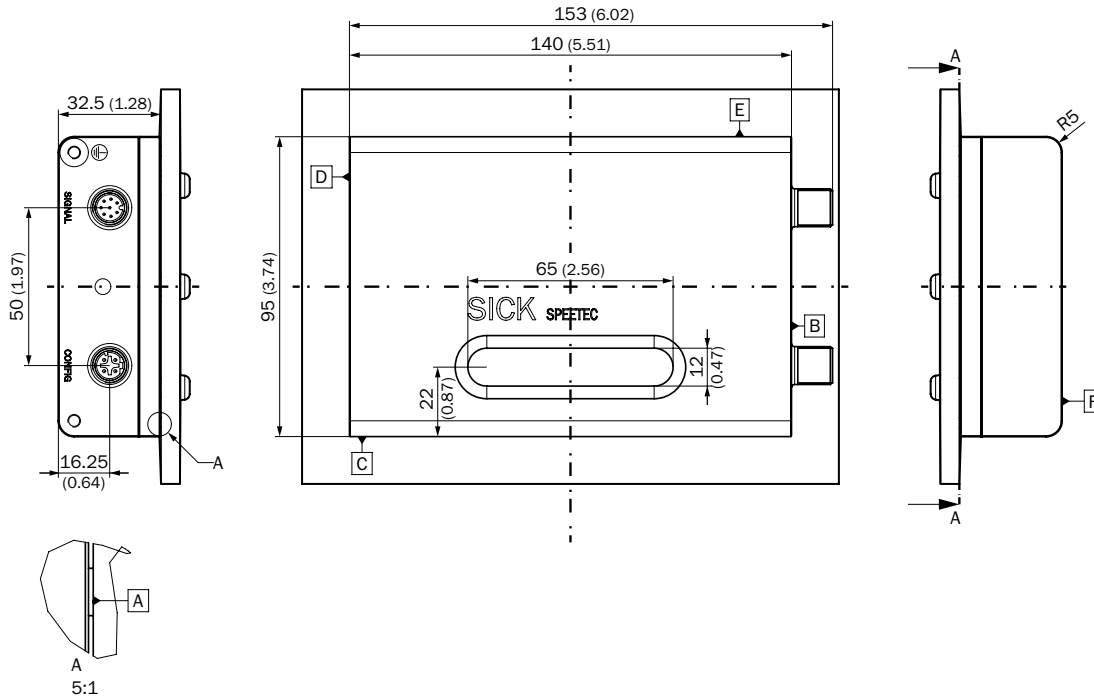

PIN assignment

M12 signal male connector,
8-pin and cable, 8-wire

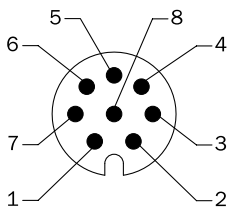

View of M12 male device connector

Male connector M12, 8-pin	Wire color	TTL, HTL standard signal	TTL, HTL signal can be programmed	Explanation
1	Brown	A-	A-	Signal cable
2	White	A	A	Signal cable
3	Black	B-	B-	Signal cable
4	Pink	B	B	Signal cable
5	Yellow	Do not wire!	Digital output	Warning: Observe signal variant!
6	Violet	Do not wire!	Digital input	Warning: Observe signal variant!
7	Blue	GND	GND	Ground connection of the sensor
8	Red	+U _s	+U _s	Supply voltage
Screen	Screen	Screen	Screen	Connect screen to housing on sensor side, connect to earth on the control side
Ground		Earthing point on housing		The sensor must be earthed via the housing at the intended earthing point.

Technical data of digital input

Type	Current Sink Type 1/3
Input voltage HIGH	15 V ... 30 V
Input voltage LOW	-3 V ... 5 V
Input current HIGH	2 mA ... 2.6 mA
Input current LOW	0 mA ... 2.6 mA

Technical data of digital output

Type	Push-Pull Output
Output voltage HIGH	$(U_s - 2 \text{ V}) \dots U_s$
Output voltage LOW	0 V ... 2 V
Output current HIGH	0.5 mA ... 30 mA

Attachment specifications

Nominal alignment of the sensor to the surface (z-axis)

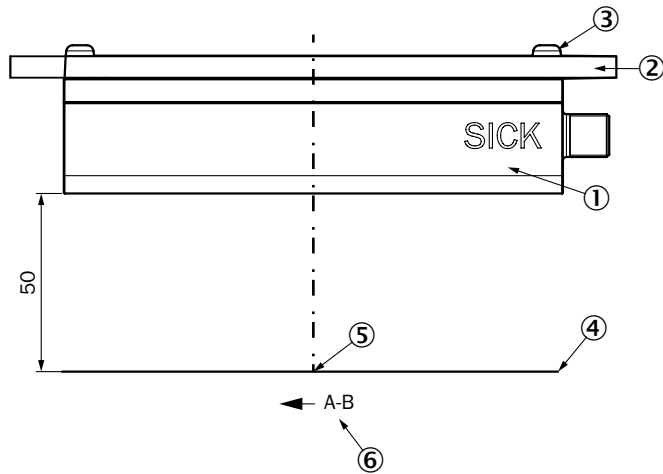

- ① Sensor
- ② Mounting surface
- ③ M4 screws
- ④ Surface to be measured
- ⑤ Measurement point on the surface
- ⑥ Forward material movement; signal sequence A before B

Nominal alignment of the sensor to the surface (x-/y-plane)

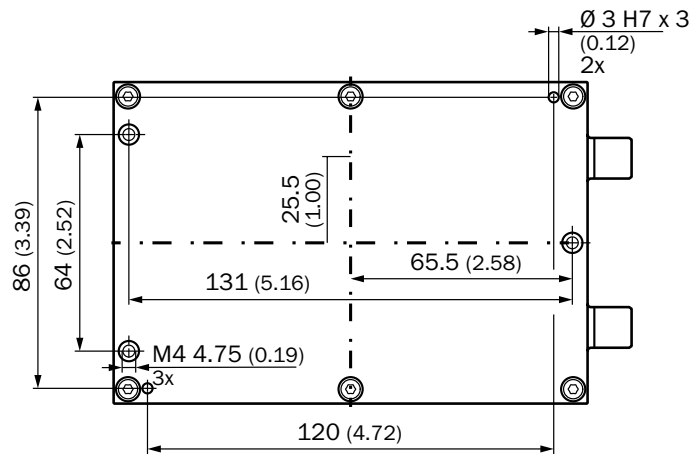

Attachment specifications

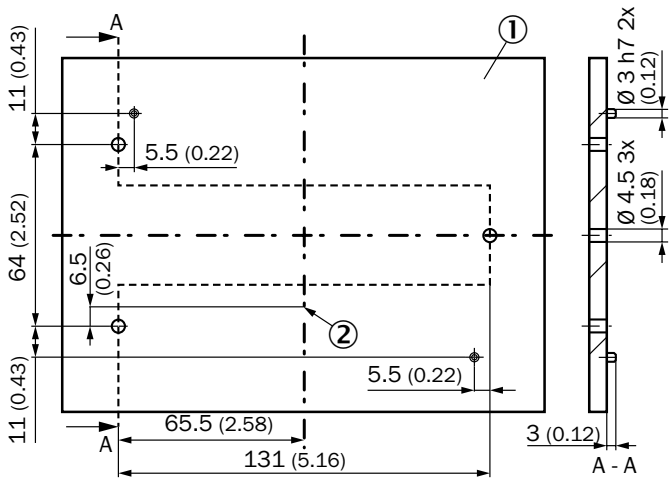

- ① Mounting surface
- ② Measurement point on x-y-plane, 82.5 mm from the mounting plane

Permissible deviations from nominal alignment

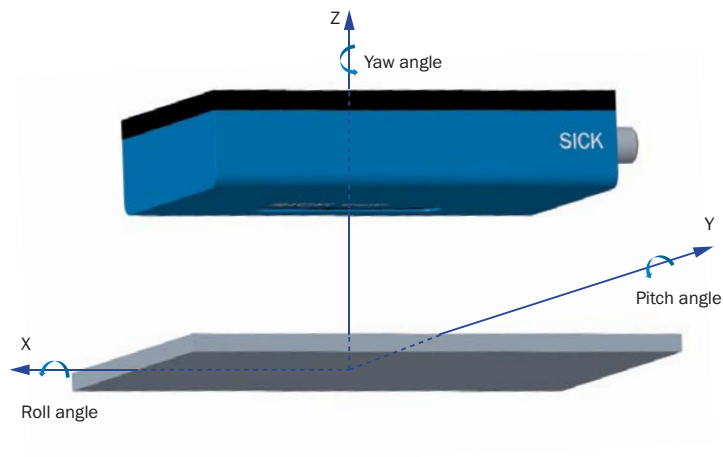

Interfaces

Signal outputs for electrical interfaces TTL and HTL with forward material movement (see assembly specifications)

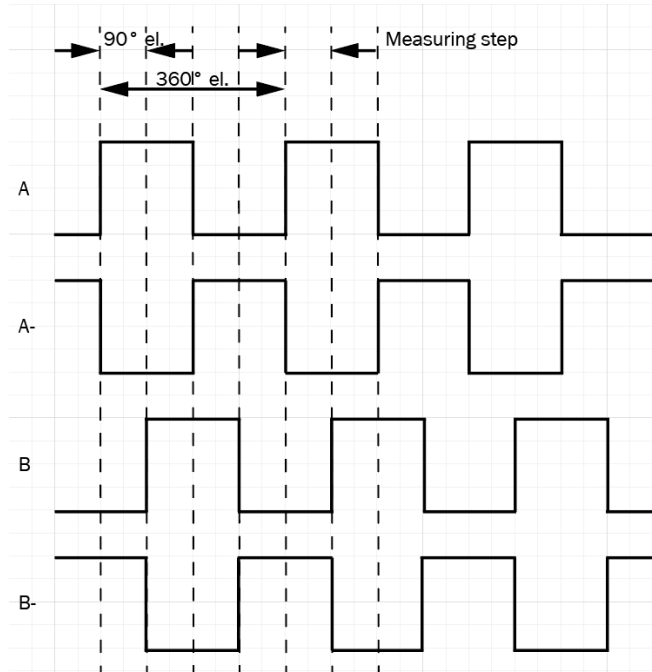

Accessories

Mounting systems

Plug connectors and cables

Connecting cables

Figure	Brief description	Length of cable	Type	Part no.
	Head A: female connector, M12, 8-pin, straight Head B: Flying leads Cable: PUR, halogen-free, shielded, 4 x 2 x 0.25 mm ² , 7 mm	2 m	DOL-1208-G02MAC1	6032866
		5 m	DOL-1208-G05MAC1	6032867
		10 m	DOL-1208-G10MAC1	6032868
		20 m	DOL-1208-G20MAC1	6032869



Dimensional drawings → [page 15](#)

Field-attachable connectors



Figure	Brief description	Type	Part no.
	Head A: female connector, M12, 8-pin, straight Head B: - Cable: shielded	DOS-1208-GA	6028369
	Head A: male connector, M12, 8-pin, straight Head B: - Cable: shielded	STE-1208-GA	6028370

Dimensional drawings → [page 15](#)

Cables (ready to assemble)

Figure	Brief description	Type	Part no.
	Head A: cable Head B: Flying leads Cable: SSI, PUR, shielded, 4 x 2 x 0.25 mm ² + 2 x 0.5 mm ² + 1 x 0.14 mm ² , 7.5 mm	LTG-2411-MW	6027530
	Head A: cable Head B: Flying leads Cable: SSI, PUR, halogen-free, shielded, 4 x 2 x 0.25 mm ² + 2 x 0.5 mm ² + 2 x 0.14 mm ² , 7.8 mm	LTG-2512-MW	6027531
	Head A: cable Head B: Flying leads Cable: SSI, TTL, HTL, PUR, halogen-free, shielded, 4 x 2 x 0.25 mm ² + 2 x 0.5 mm ² + 2 x 0.14 mm ² , 7.8 mm, UV and saltwater-resistant	LTG-2612-MW	6028516

Connection cables

Figure	Brief description	Length of cable	Type	Part no.
	Head A: female connector, M12, 8-pin, straight Head B: male connector, M12, 8-pin, straight Cable: PUR, halogen-free, shielded, 7.7 mm	5 m	DSL-1208-G05MAC1	6032913
	Signal distribution cable	0.2 m	YM2A28-C20S01MYAAX	2124388



Dimensional drawings → [page 15](#)

Alignment aids

Figure	Brief description	Type	Part no.
	Adjustment aid for NCV50	BEF-WN-NCV50-ADJST	2117003
	IR converter card for SPEETEC 1D	BEF-SPEETEC-LSD	2120614

Dimensional drawings → [page 15](#)

Mounting brackets

Figure	Brief description	Type	Part no.
	Mounting bracket for photoelectric proximity switch on NCV50	BEF-MK-NCV50-W49G6	2117457
	Mounting bracket for NCV50	BEF-WN-NCV50 mounting bracket	2117456
	Mounting bracket for measuring wheel system MWS120 and laser surface motion sensors SPEETEC 1D	BEF-WF-MWS-NCV	2113284

Dimensional drawings → [page 16](#)

Programming and configuration tools

Figure	Brief description	Type	Part no.
	Programming tool for SPEETEC 1D	PGT-14	1121562

Dimensional drawings → [page 17](#)

Dimensional drawings for accessories (Dimensions in mm (inch))

Plug connectors and cables

DOL-1208-GxxMAC1

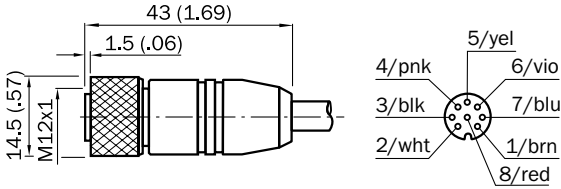

All dimensions in mm (inch)

DOS-1208-GA01

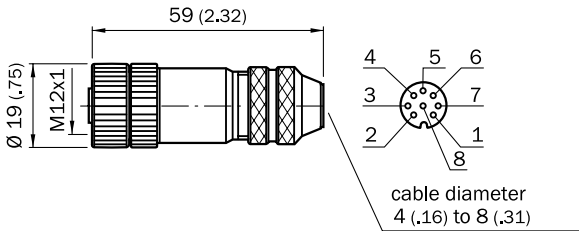

STE-1208-GA01

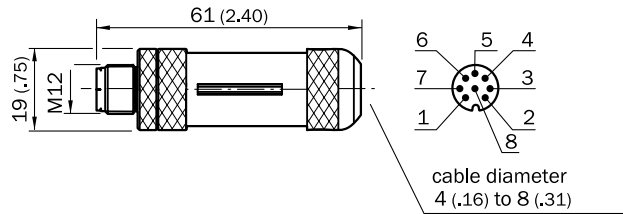

DSL-1208-G05MAC1

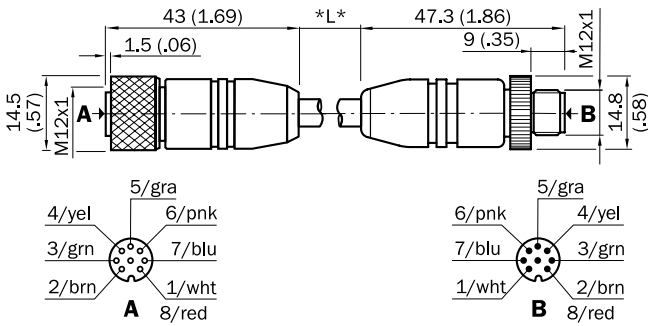

Alignment brackets

BEF-WN-NCV50-ADJST

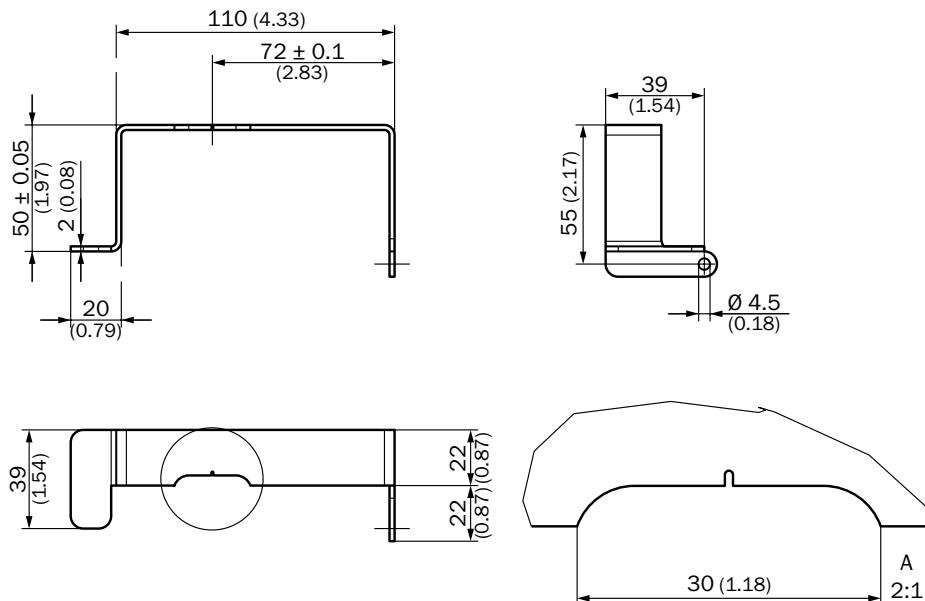

Mounting brackets

BEF-MK-NCV50-W49G6

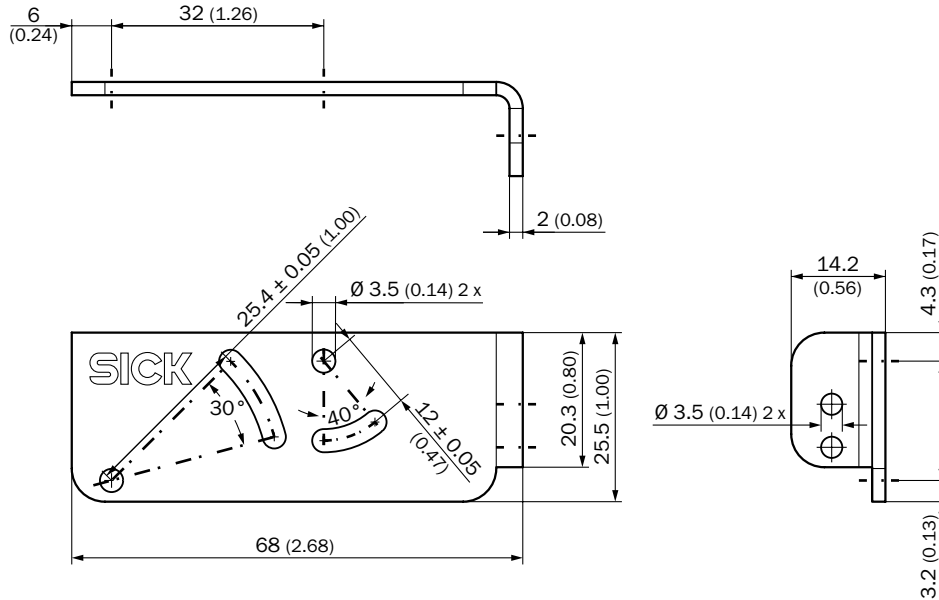

BEF-WN-NCV50-Monting bracket

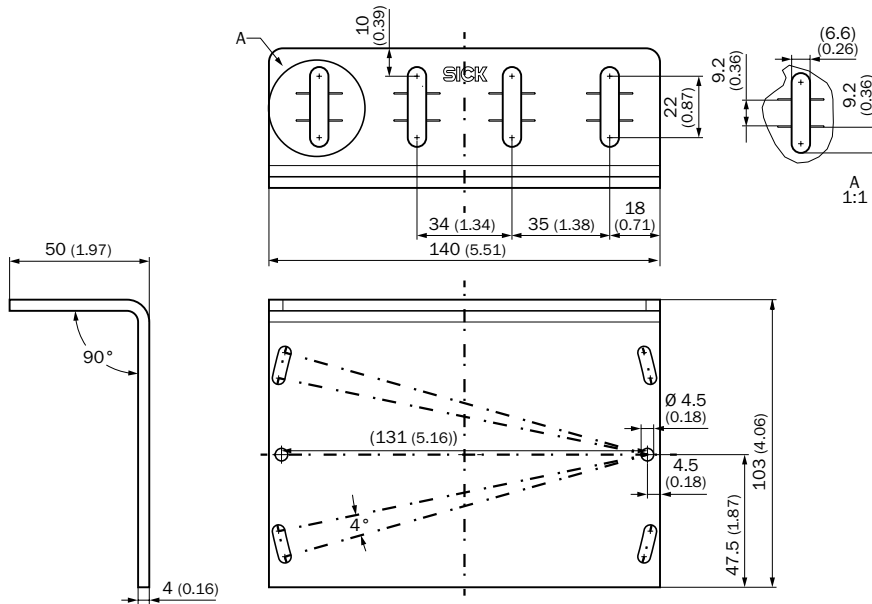

BEF-MWS-NCV

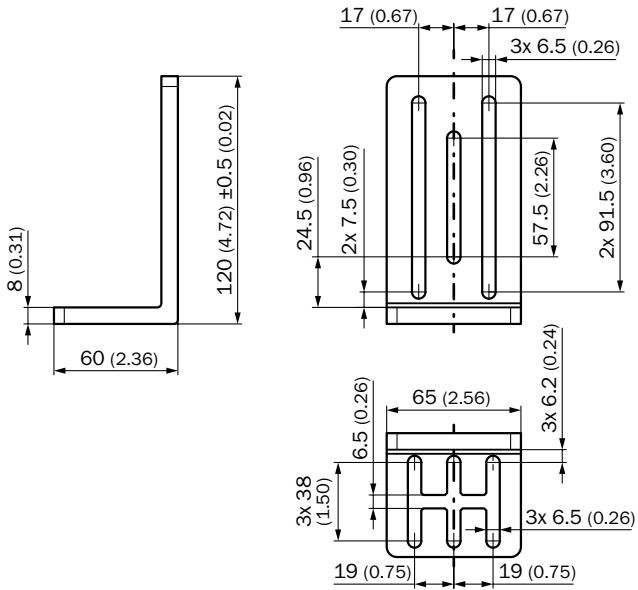

Programming and configuration tools

PGT-14

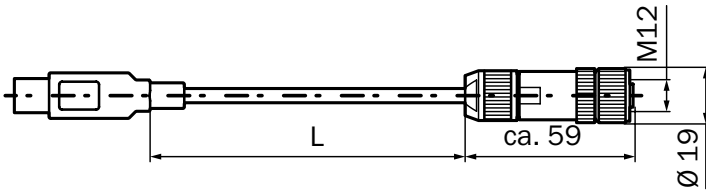

WORKING WITH SICK IN A DIGITAL WORLD

Making your digital business environment comfortable

Find a suitable solution in next to no time

- Online product catalog
- Application Solver
- Online configurators and selectors

My SICK is your personal self-service portal

- Open around the clock
- Clear product information
- Company-specific price conditions
- Convenience during the ordering process
- Document overview
- Availability and delivery times

Register now:

→ www.sick.com/myBenefits

Even more value

- Digital Customer Trainings → www.sick.com/c/g300887
- Digital Service Catalog → cloud.sick.com
- SICK AppPool → apppool.cloud.sick.com



SERVICES FOR MACHINES AND PLANTS: SICK LifeTime Services

Our comprehensive and versatile LifeTime Services are the perfect addition to the comprehensive range of products from SICK. The services range from product-independent consulting to traditional product services.



Consulting and design
Safe and professional



Product and system support
Reliable, fast, and on-site



Verification and optimization
Safe and regularly inspected



Upgrade and retrofits
Easy, safe, and economical



Training and education
Practical, focused, and professional

SICK AT A GLANCE

SICK is a leading manufacturer of intelligent sensors and sensor solutions for industrial applications. With more than 10,400 employees and over 50 subsidiaries and equity investments as well as numerous agencies worldwide, SICK is always close to its customers. A unique range of products and services creates the perfect basis for controlling processes securely and efficiently, protecting individuals from accidents, and preventing damage to the environment.

SICK has extensive experience in various industries and understands their processes and requirements. With intelligent sensors, SICK delivers exactly what the customers need. In application centers in Europe, Asia, and North America, system solutions are tested and optimized in accordance with customer specifications. All this makes SICK a reliable supplier and development partner.

Comprehensive services round out the offering: SICK LifeTime Services provide support throughout the machine life cycle and ensure safety and productivity.

That is “Sensor Intelligence.”

Worldwide presence:

Australia, Austria, Belgium, Brazil, Canada, Chile, China, Czech Republic, Denmark, Finland, France, Germany, Great Britain, Hungary, Hong Kong, India, Israel, Italy, Japan, Malaysia, Mexico, Netherlands, New Zealand, Norway, Poland, Romania, Russia, Singapore, Slovakia, Slovenia, South Africa, South Korea, Spain, Sweden, Switzerland, Taiwan, Thailand, Turkey, United Arab Emirates, USA, Vietnam.

Detailed addresses and further locations → www.sick.com