

# SMARTSTEP 2 SERVO SYSTEM

A new step in servodrive simplicity



» Precise and cost-effective

» Ultra-compact design

» Simple to use and set up

# SmartStep 2 - the right step forward...

*Omron knows that simplicity and precision are vital in your positioning application.*

*The new SmartStep offers an ideal solution for point-to-point motion applications where simplicity is essential. SmartStep2 keeps things simple whilst combining high performance in a cost-effective solution.*

*SmartStep2 has a completely new compact design that gives a 50% space saving compared with the previous model. It also has new features and functionality to help you to make your machines more efficient and cost-effective.*

## Features at a glance:

- Pulse control servo drive
- Ultra-compact size
- Auto-tuning
- Vibration suppression
- Adaptive resonance suppression filter
- Two programmable torque limits
- Feedback pulse output
- Power range from 50 W to 750 W
- Cylindrical and flat servo motors
- Electronic gear
- 10,000 steps per revolution

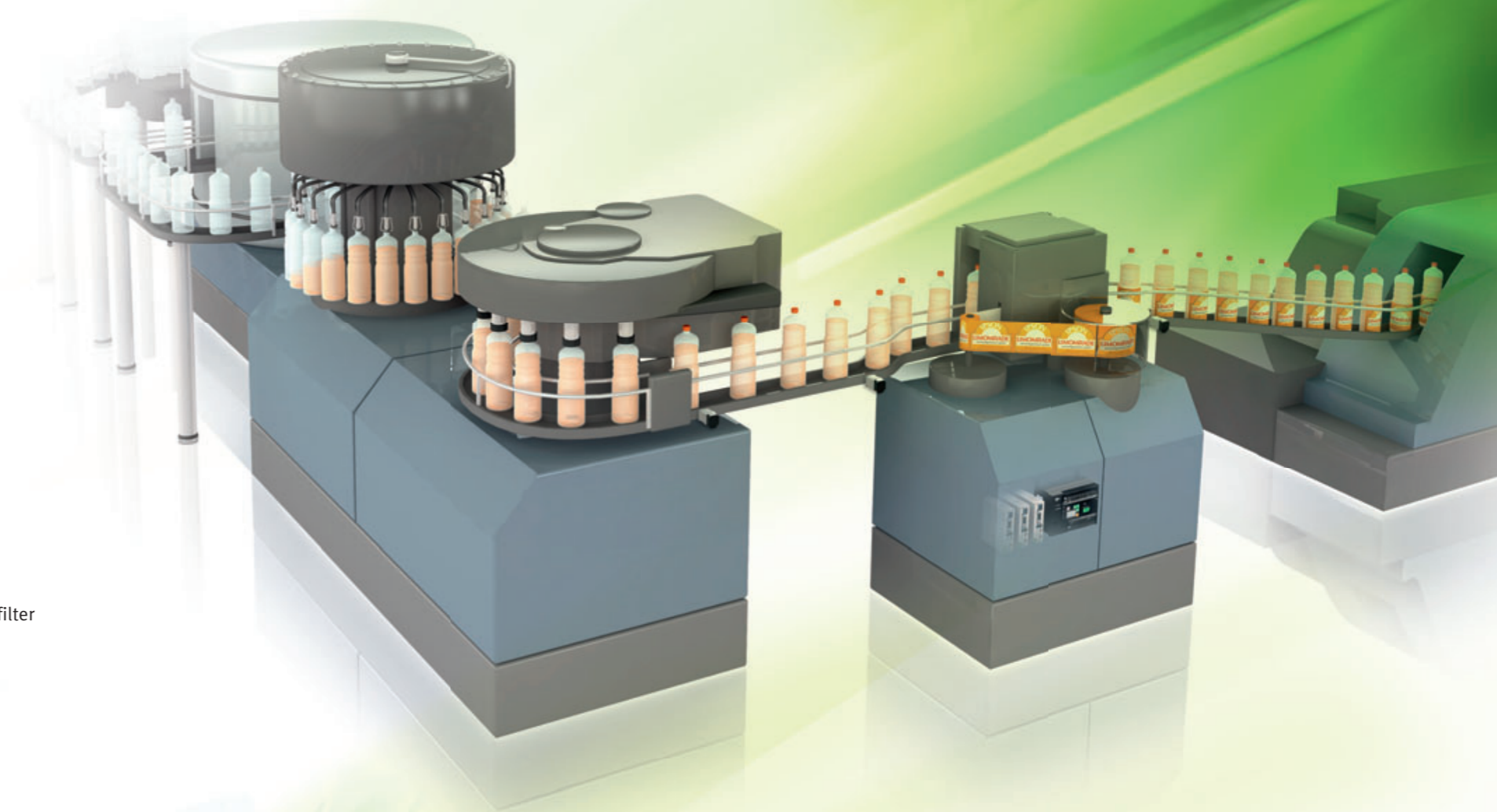

## ...to faster development with great drive simplicity

### Getting started quickly

CX-Drive is a single, easy-to-use software tool for configuring, commissioning and maintaining both inverters and servos. SmartStep 2 is fully supported with a wide range of features making the servo drive set-up easier and faster than ever:

- Auto-tuning
- Parameter editing and monitoring
- Speed and position diagrams
- I/O status and alarms
- Real-time data trace

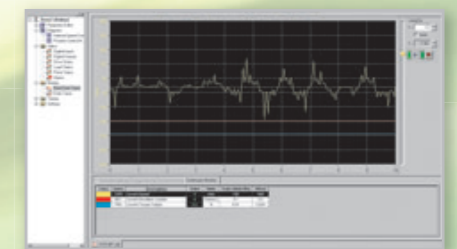

Real-time data trace

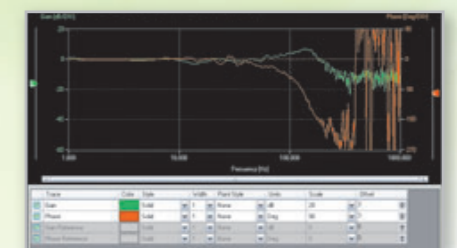

Frequency analysis

# A compact design that's easy to connect

Although it has more functionality than previous models, SmartStep 2 has a compact design with an ultra-small footprint that saves considerable space. In addition, SmartStep 2 can be easily integrated with other automation devices such as the CP1L compact machine controller and NS operator terminals, helping to make an efficient and cost-effective machine design.

## Additional features:

- Position control via pulse input 500 kpps
- Rated speed 4,000 rpm; peak 5,000 rpm
- Wide range of pulse configurations
- Four internal speed settings switched by external signal for easy control
- Servomotors compatible with SmartStep



## Compact space-saving design

SmartStep 2 has a footprint 48% smaller than that of previous models and the volume is 39% smaller, saving cabinet space and costs.

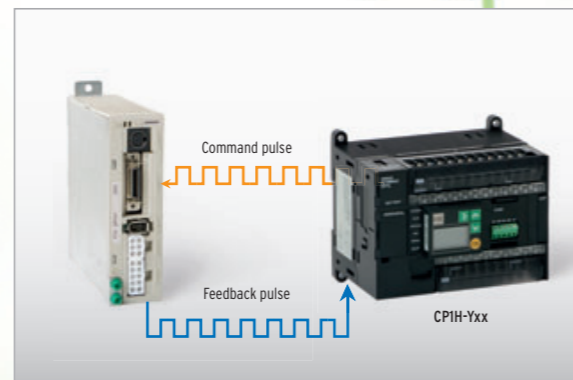

## Feedback pulse output

Enables servo position feedback to the controller for close control position loop and monitor real positioning; it can be also used to synchronise with another axis.



## Adjustment-free operation

Depending on load variations, the real-time auto-tuning function automatically calculates and adjusts the optimum gain values for the machine.

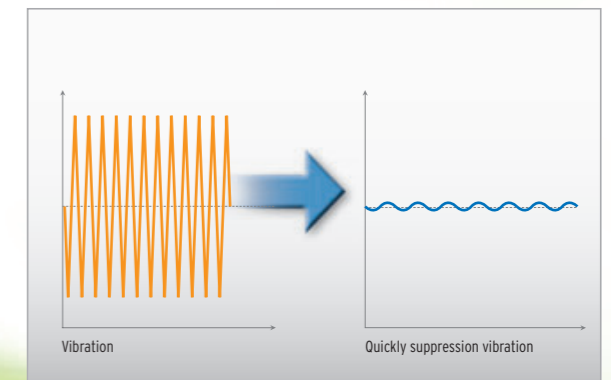

## Vibration suppression

An adaptive filter ensures that resonant frequency changes are automatically followed to reduce the effect of vibration due to low mechanical rigidity. A further filter minimises vibration for better positioning when stopping the load.

R7D-BP□, R88D-GP□, R88M-G□

# SmartStep 2 servo system

**Another step forward in drive simplicity**

- On-line Auto-tuning and Easy set up
- Ultra-compact size. The footprint is only 48% that of the SmartStep series
- Two torque limits
- Electronic gear, four internal speed settings and wide range of pulse settings
- Adaptive filters for suppression of vibration and resonance
- Servomotors with IP65 as standard and shaft oil seal available
- Motors with brake as option

**Ratings**

- 230 VAC single-phase 50 W to 750 W (0.16 to 2.4 Nm)



**System configuration**

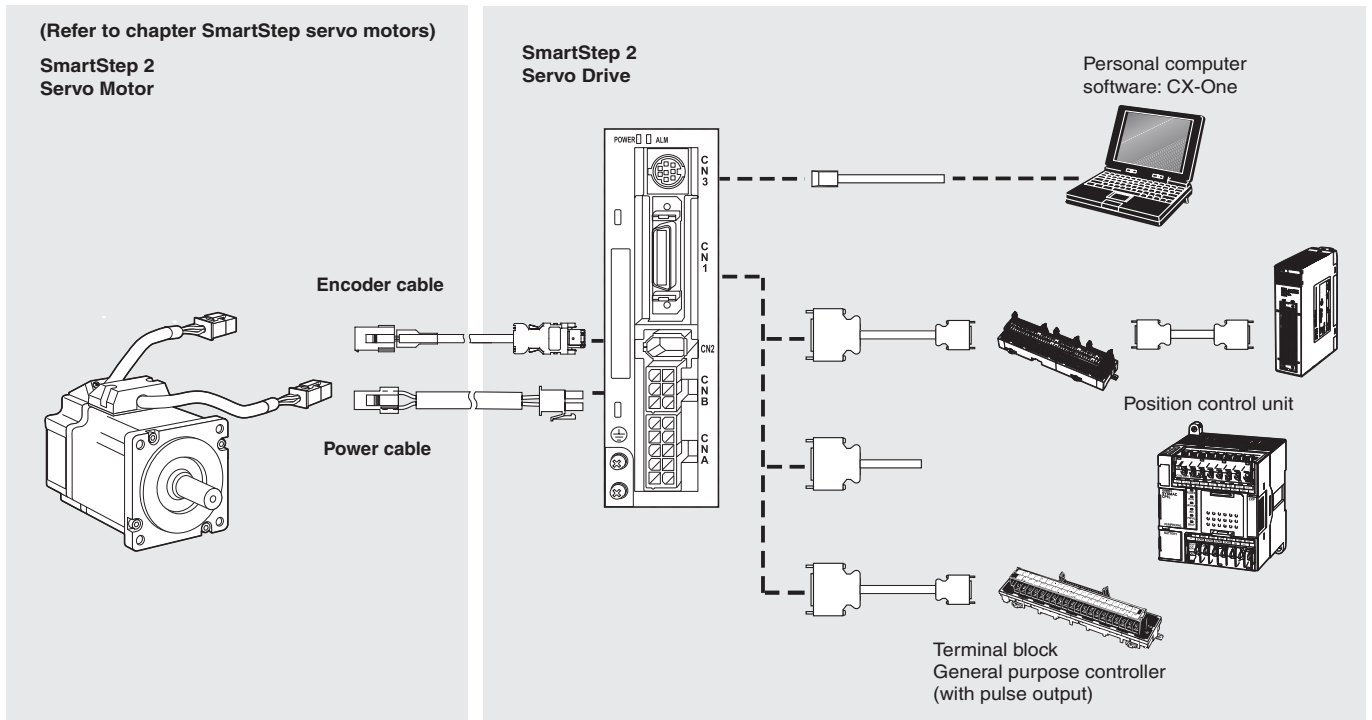

**Servo drive type designation**

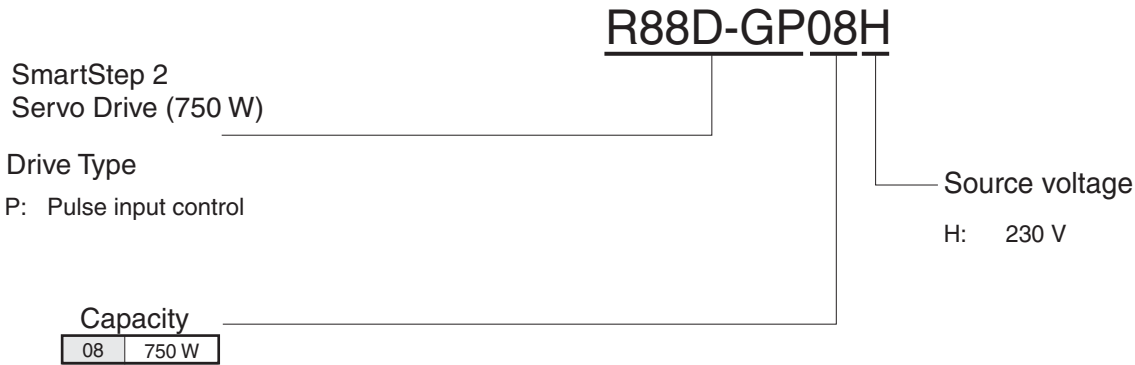
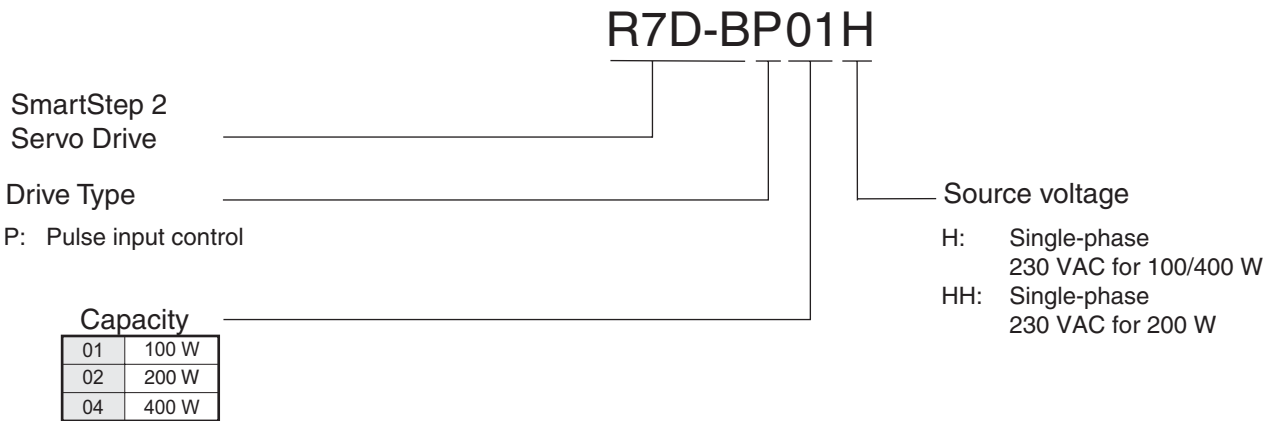

**Servo drive specifications**

**General specifications**

Item	Specification
Ambient operating temperature	0 to 55°C
Ambient operating humidity	90% max. (with no condensation)
Ambient storage temperature	-20 to 65°C
Ambient storage humidity	90% max. (with no condensation)
Storage/operating atmosphere	No corrosive gases.
Vibration resistance	10 to 60 Hz; acceleration : 5.9 m/s <sup>2</sup> (0.6G) max.
Impact resistance	Acceleration 19.6 m/s <sup>2</sup> max., 3 times each in X, Y, and Z directions,
Insulation resistance	Between power supply/power line terminals and frame ground: 0.5 MΩ min. (at 500 VDC)
Dielectric strength	Between power supply/power terminals and frame ground: 1,500 VAC for 1 min at 50/60 Hz Between each control signal and frame ground: 500 VAC for 1 min
Protective structure	Built into panel (IP10).
International standards	Approval obtained for UL: UL 508C; cUL: cUL C22.2 No 14 Approval EC : EMC EN55011 class A Group 1, EN 61000-6-2, low voltage EN50178

**Performance specifications**

Item	200 VAC input type			
	100 W R7D-BP01H	200 W R7D-BP02HH	400 W R7D-BP04H	750 W R88D-GP08H
Continuous output current (rms)	1.0 A	1.6 A	2.5 A	4 A
Momentary maximum output current (rms)	3.3 A	4.9 A	7.8 A	14.1 A
Main-circuit power supply	Single-phase 200 to 240 VAC (170 to 264 V), 50/60 Hz			Single-phase/three-phase 200 to 240 VAC (170 to 264 V), 50/60 Hz

Item	200 VAC input type			
	100 W	200 W	400 W	750 W
	R7D-BP01H	R7D-BP02HH	R7D-BP04H	R88D-GP08H
Control circuit input power	-			Single-phase 200 to 240 VAC (170 to 264 V)
Control method	All-digital method			
Feedback	10,000 pulses/revolution incremental encoder			
Inverter method	PWM method based on IGBT			
PWM frequency	12 kHz		6 kHz	
Weight	0.35 kg	0.42 kg	0.42 kg	1.5 kg
Compatible motor voltage	200 V			
Command pulse response	Line drive: 500 kpps			
Compatible motor capacity	50 W 100 W	200 W	400 W	750 W
Applicable servo motor (R88M-)	G05030H G10030H GP10030H	G020030H GP20030H	G40030H GP40030H	G75030H

**Servodrive part names**

**SmartStep2 Servo Drive (100 - 400 W models)**

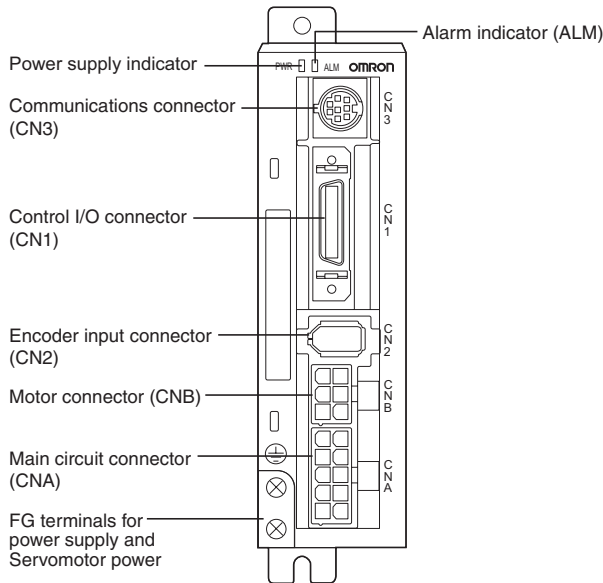

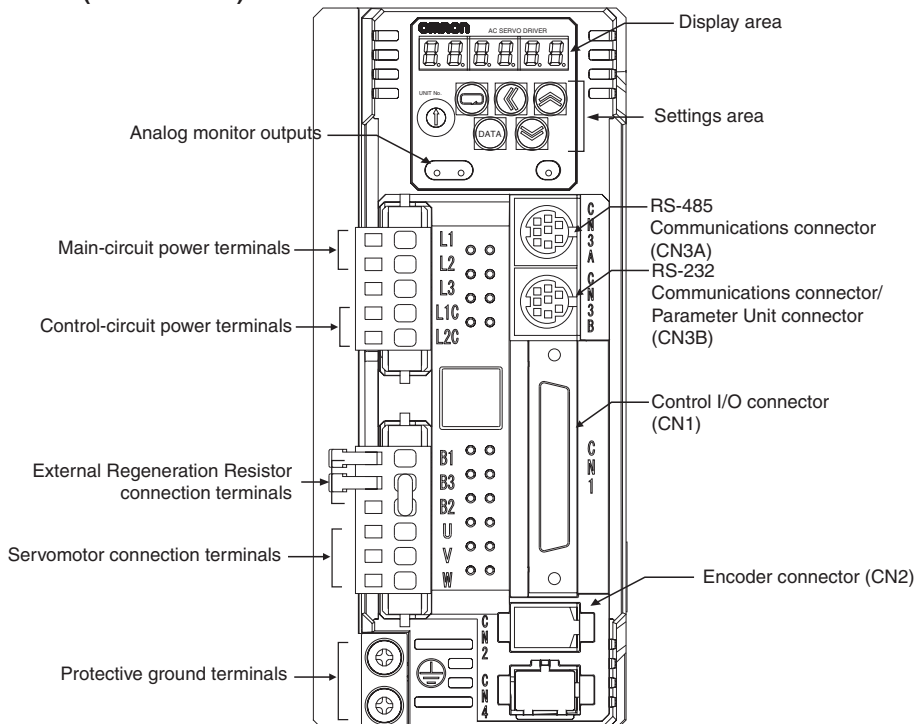

**SmartStep2 Servo Drive (750 W model)**

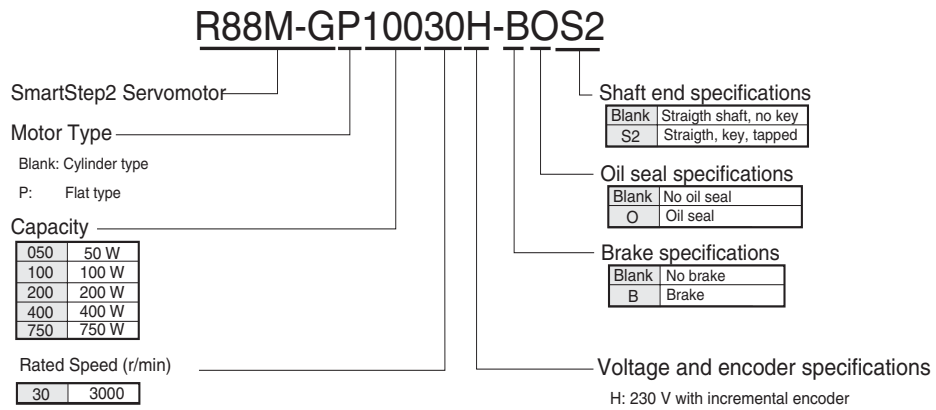

**Servomotor type designation**



**Servo motor / servo drive combination**

Servo motor						
Family		Voltage	Speed	Rated torque	Capacity	Model
Cylindric	50-750 W 	230 V	3000 min <sup>-1</sup>	0.16 Nm	50 W	R88M-G05030H-□S2
				0.32 Nm	100 W	R88M-G10030H-□S2
				0.64 Nm	200 W	R88M-G20030H-□S2
				1.3 Nm	400 W	R88M-G40030H-□S2
				2.4 Nm	750 W	R88M-G75030H-□S2
Flat	100-400 W 			0.32 Nm	100 W	R88M-GP10030H-□S2
				0.64 Nm	200 W	R88M-GP20030H-□S2
				1.3 Nm	400 W	R88M-GP40030H-□S2

**Servo motor specifications**

**General specifications**

Item	Specification
Ambient operating temperature	0 to 40°C
Ambient operating humidity	85% max. (with no condensation)
Ambient storage temperature	-20 to 65°C
Ambient storage humidity	85% max. (with no condensation)
Storage/operating atmosphere	No corrosive gases
Vibration resistance	49 m/s <sup>2</sup> max. in the X, Y, and Z directions
Impact resistance	Acceleration of 98 m/s <sup>2</sup> max. 3 times each in the X, Y, and Z directions
Insulation resistance	20 MΩ min. at 500 VDC between the power terminals and FG terminal
Dielectric strength	1,500 VAC (50 or 60 Hz) for 1 minute between the power terminals and FG terminal
Run position	Any direction
Insulation grade	Type B
Structure	Totally-enclosed, self-cooling
Protective structure	IP65 (excluding the through-shaft portion)
Vibration grade	V-15
Mounting method	Flange-mounting
International standards	Approval obtained for UL, cUL, and EN (EMC directive and low-voltage directive)

**Performance specifications**

**Cylindric servo motors**

Item	Unit	R88M-G05030H	R88M-G10030H	R88M-G20030H	R88M-G40030H	R88M-G75030H
Rated output	W	50	100	200	400	750
Rated torque	N·m	0.16	0.32	0.64	1.3	2.4
Rated rotation speed	r/min	3000				
Momentary maximum rotation speed	r/min	5000				
Momentary maximum torque	N·m	0.48	0.95	1.78	3.60	7.05
Rated current	A (rms)	1.1		1.6	2.6	4
Momentary maximum current	A (rms)	3.4		4.9	7.9	12.1
Rotor inertia	kg·m <sup>2</sup>	2.5 × 10 <sup>-6</sup>	5.1 × 10 <sup>-6</sup>	1.4 × 10 <sup>-5</sup>	2.6 × 10 <sup>-5</sup>	8.7 × 10 <sup>-5</sup>
Power rate	kW/s	10.4	20.1	30.3	62.5	66
Allowable radial load	N	68		245		392
Allowable thrust load	N	58		98		147
Weight	Without brake	kg	0.3	0.5	0.8	1.2
	With brake	kg	0.5	0.7	1.3	1.7
Encoder resolution	---	Phase A and B: 2,500 pulses/rotation, Phase Z: 1 pulse/rotation				
Radiation shield dimensions	---	100 × 80 × t10 (Al)		130 × 120 × t12 (Al)		-
Brake specifications	Brake inertia	kg·m <sup>2</sup>	2.0 × 10 <sup>-7</sup>	2.0 × 10 <sup>-7</sup>	1.8 × 10 <sup>-6</sup>	7.5 × 10 <sup>-6</sup>
	Excitation voltage	V	24 VDC ±10%			
	Power consumption (at 20 °C)	W	7		9	
	Current consumption (at 20 °C)	A	0.30		0.36	
	Static friction torque	N·m	0.29 min.		1.27 min.	
	Attraction time	ms	35 max.		50 max.	
	Release time	ms	20 max.		15 max.	
	Backlash	-	±1° max.			
	Rating	-	Continuous			
	Brake life	-	10,000,000 operations min.			
Applicable servo driver		R7D-BP01H		R7D-BP02HH	R7D-BP04H	R88D-GP08H

**Torque-speed characteristics**

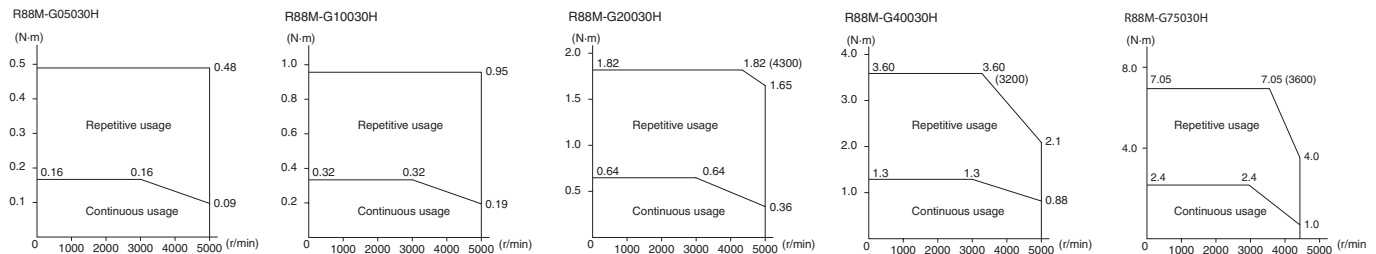



Flat servo motors

Item	Unit	R88M-GP10030H	R88M-G20030H	R88M-G40030H	
Rated output	W	100	200	400	
Rated torque	N·m	0.32	0.64	1.3	
Rated rotation speed	r/min	3000			
Momentary maximum rotation speed	r/min	5000			
Momentary maximum torque	N·m	0.90	1.82	3.60	
Rated current	A (rms)	1.0	1.6	4.4	
Momentary maximum current	A (rms)	4.3	6.8	18.6	
Rotor inertia	kg·m <sup>2</sup>	9.0 × 10 <sup>-6</sup>	3.4 × 10 <sup>-5</sup>	6.4 × 10 <sup>-5</sup>	
Power rate	kW/s	11.4	11.8	25.5	
Allowable radial load	N	68	245		
Allowable thrust load	N	58	98		
Weight	Without brake	kg	0.7	1.3	
	With brake	kg	0.9	2.0	
Encoder resolution	---	Phase A and B: 2,500 pulses/rotation, Phase Z: 1 pulse/rotation			
Radiation shield dimensions	---	130 × 120 × t10 (Al)		170 × 160 × t12 (Al)	
Brake specifications	Brake inertia	kg·m <sup>2</sup>	3.0 × 10 <sup>-6</sup>	9.0 × 10 <sup>-6</sup>	
	Excitation voltage	V	24 VDC ±10%		
	Power consumption (at 20 °C)	W	7	10	
	Current consumption (at 20 °C)	A	0.29	0.41	
	Static friction torque	N·m	0.29 min.		1.27 min.
	Attraction time	ms	50 max.	60 max.	
	Release time	ms	15 max.		
	Backlash	-	±1° max.		
	Rating	-	Continuous		
	Brake life	-	10,000,000 operations min.		
Applicable servo driver (R7D-)		BP01H	BP02HH	BP04H	

Torque-speed characteristics

R88M-GP10030H

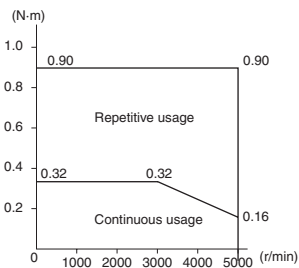

R88M-GP20030H

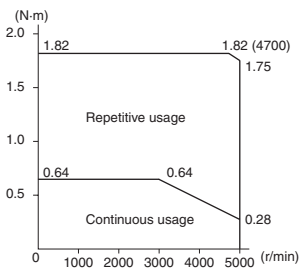

R88M-GP40030H

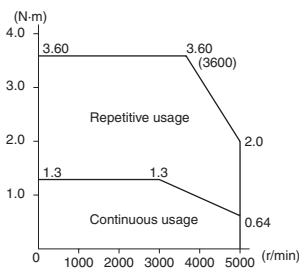

**Dimensions**

**Servo drives**

**R7D-BP01H**

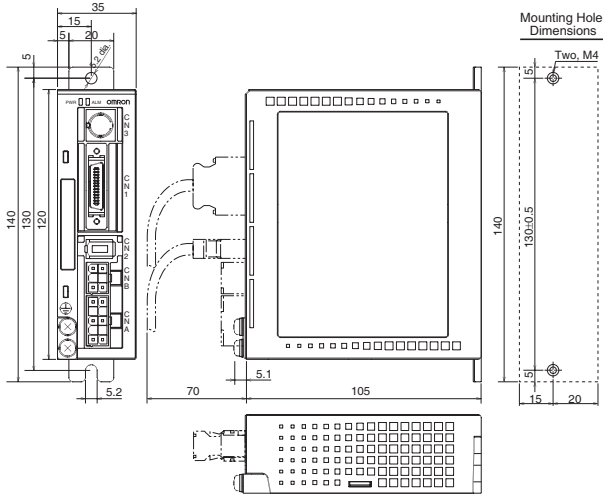

**R7D-BP02HH/ 04H**

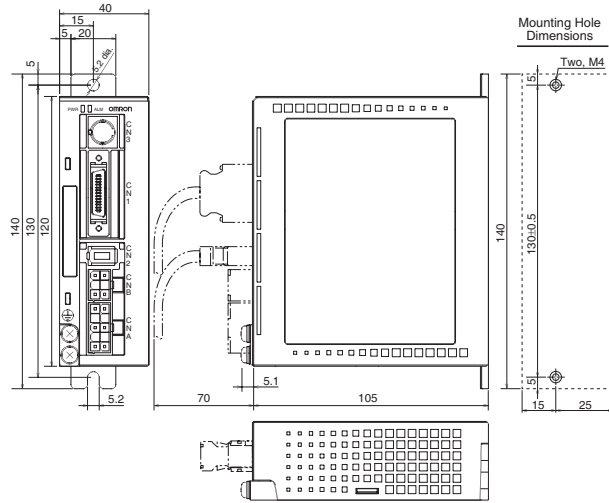

**R88D-GP08H**

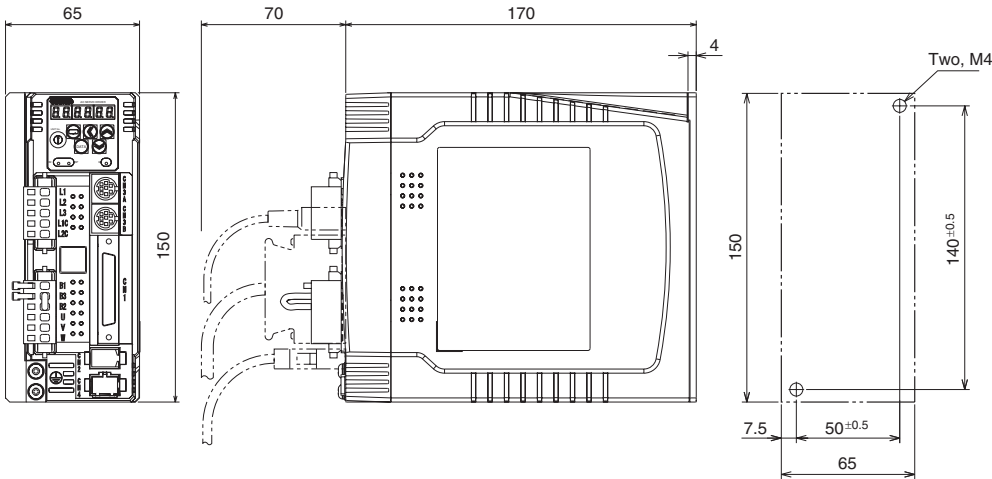

**Filters**

**R7A-FIB104-RE**

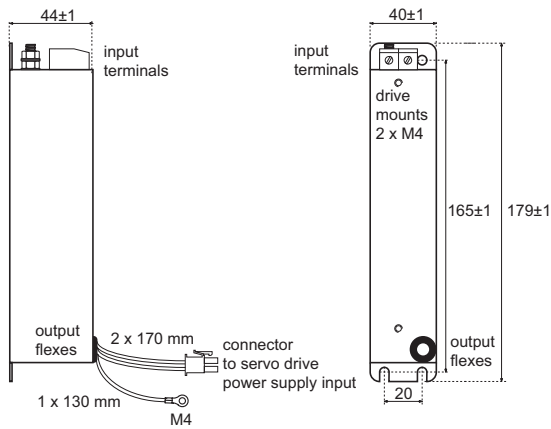

**R88A-FIK107-RE**

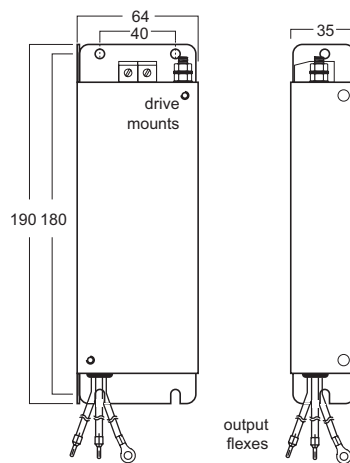

Filter model	Rated current	Leakage current	Rated voltage
R7A-FIB104-RE	4 A	3.5 mA	250 VAC single-phase
R88A-FIK107-RE	6.6 A	3.5 mA	250 VAC single-phase

Servo motors

Cylindrical type 3000 r/min (230 V, 50 - 100W)

Dimensions (mm)	Without brake		With brake		LN	Aprox. Mass (Kg)	
	LL	LL	LL	LL		Without brake	With brake
R88M-G05030H-□S2	72		102		26.5	0.3	0.5
R88M-G10030H-□S2	92		122		46.5	0.5	0.7

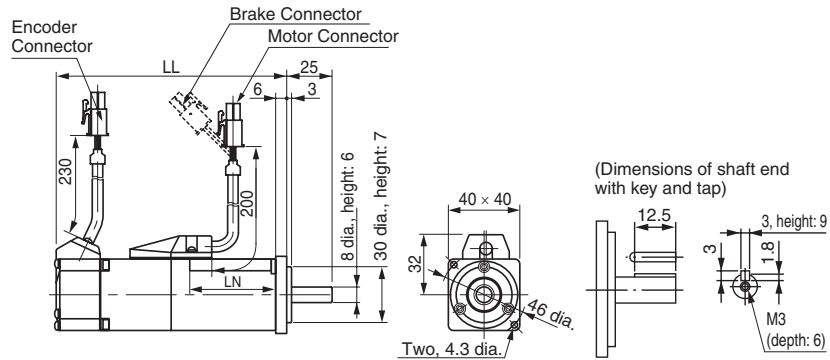

Cylindrical type 3000 r/min (230 V, 200 - 750W)

Dimensions (mm)	Without brake		With brake		Flange surface					Shaft end						Aprox. Mass (Kg)		
	LL	LL	LR	KL1	D1	D2	C	G	Z	S	QK	b	h	M	t1	L	Without brake	With brake
R88M-G20030H-□S2	79.5	116	30	43	70	50	60	6.5	4.5	11	18	4h9	4	M4	2.5	8	0.8	1.3
R88M-G40030H-□S2	99	135.5								14	22.5	5h9	5	M5	3	10	1.2	1.7
R88M-G75030H-□S2	112.2	149.2	35	53	90	70	80	8	6	19	22	6h9	6	M5	3.5	10	2.3	3.1

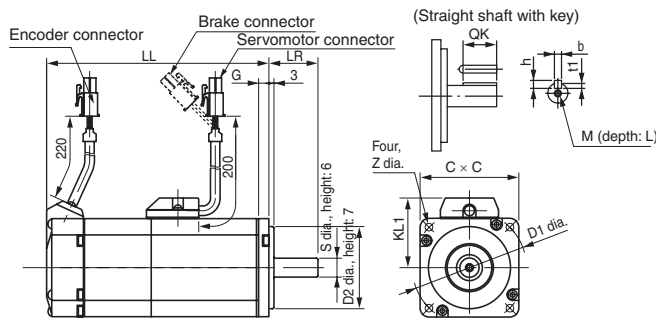

Flat type 3000 r/min (230 V, 100 W - 400 W)

Dimensions (mm)	Without brake		With brake		Flange surface					Shaft end						Aprox. Mass (Kg)		
	LL	LL	LR	KL1	D1	D2	C	F	G	Z	S	QK	b	h	t1	Tap x depth	Without brake	With brake
R88M-GP10030H-□S2	60.5	84.5	25	43	70	50	60	3	7	4.5	8	12.5	3h9	3	1.8	M3x6	0.7	0.9
R88M-GP20030H-□S2	67.5	100	30	53	90	70	80	5	8	5.5	11	18	4h9	4	2.5	M4x8	1.3	2
R88M-GP40030H-□S2	82.5	115									14	22.5	5h9	5	3.0	M5x10	1.8	2.5

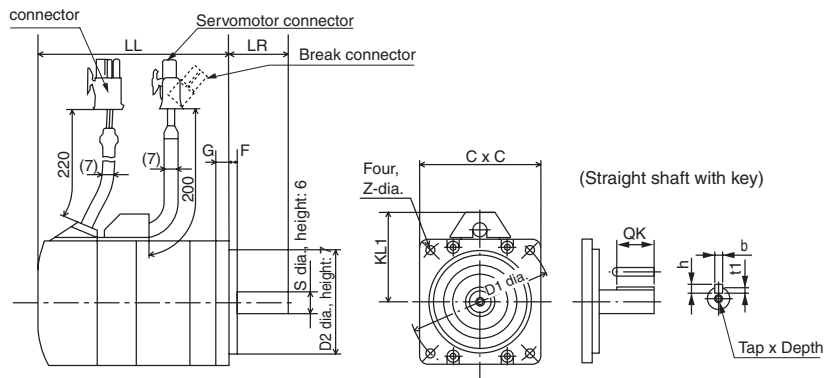

Installation

Single-phase, 230 VAC

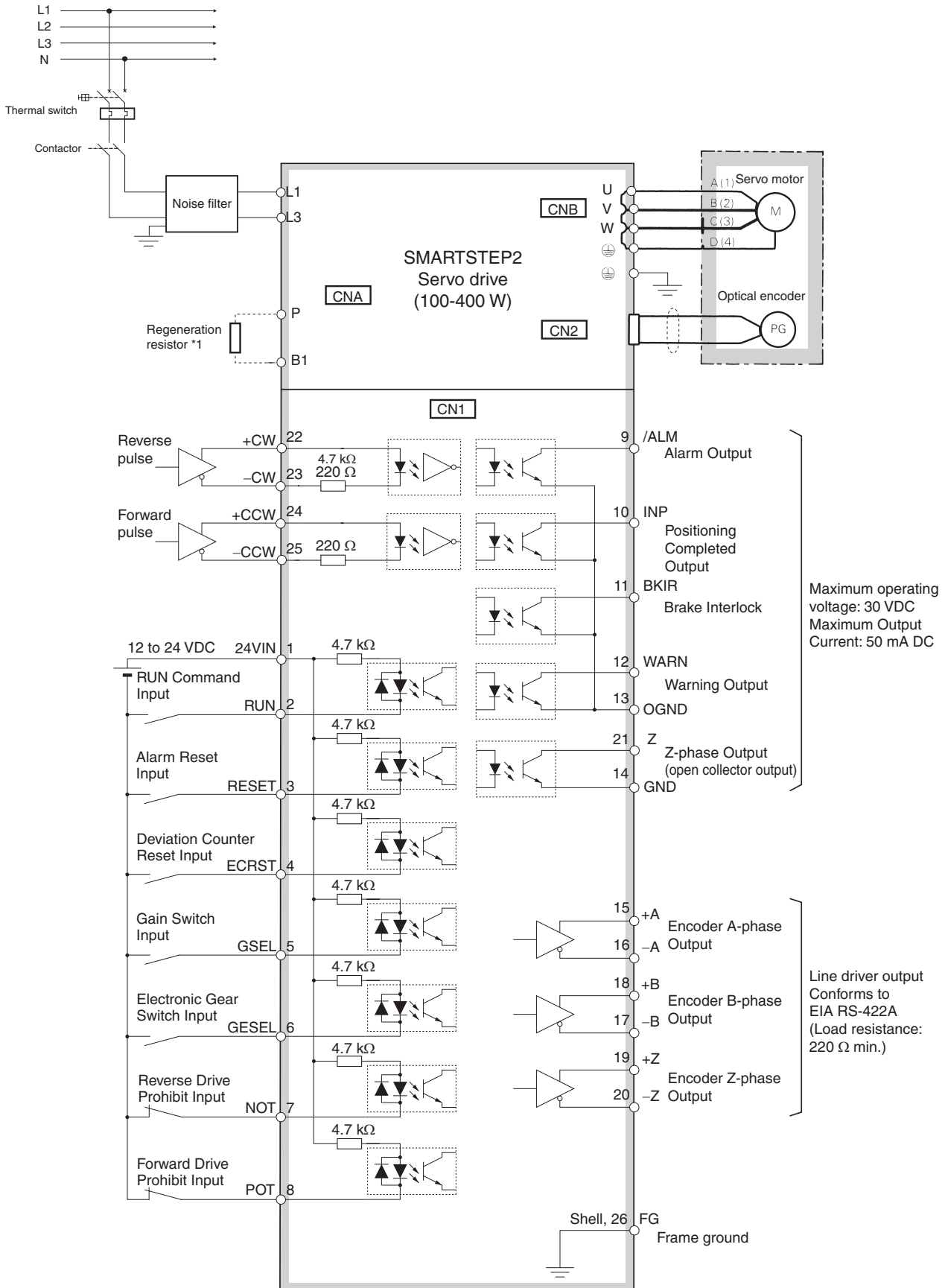

\*1. An External Regeneration Resistor can be connected. Connect this resistor if the regenerative energy exceeds regeneration absorption capacity in the Servo Drive.  
**Note:** 1. The dynamic brake operates when the main circuit power supply or the control circuit power supply is turned OFF.  
**Note:** 2. When turning OFF the main circuit power supply, turn OFF the RUN Command Input (RUN) signal at the same time.

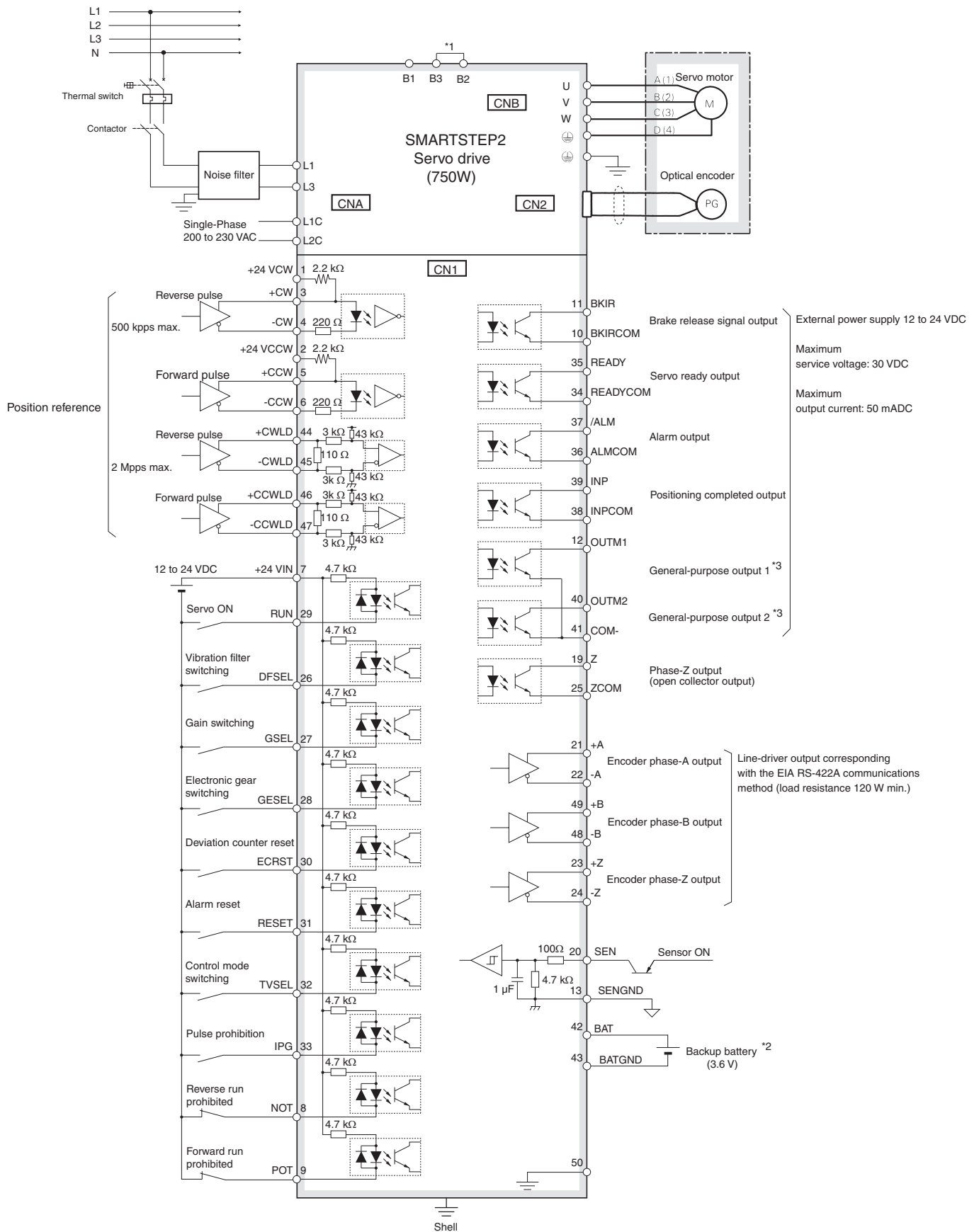

\*1 B3-B2 are short-circuited. If the internal regenerative resistor is insufficient, remove the wire between B2 and B3 and connect an external regenerative resistor between B1 and B2.

\*2 Use only when an absolute encoder. If a backup battery is connected, an encoder cable with a battery is not required.

\*3 The default values are ZSP (zero-speed detection) for OUTM1 and T-LIMIT (at torque limit) for OUTM2.

**Ordering information**

**SmartStep2 Servo Drive Configuration (100-400 W)**

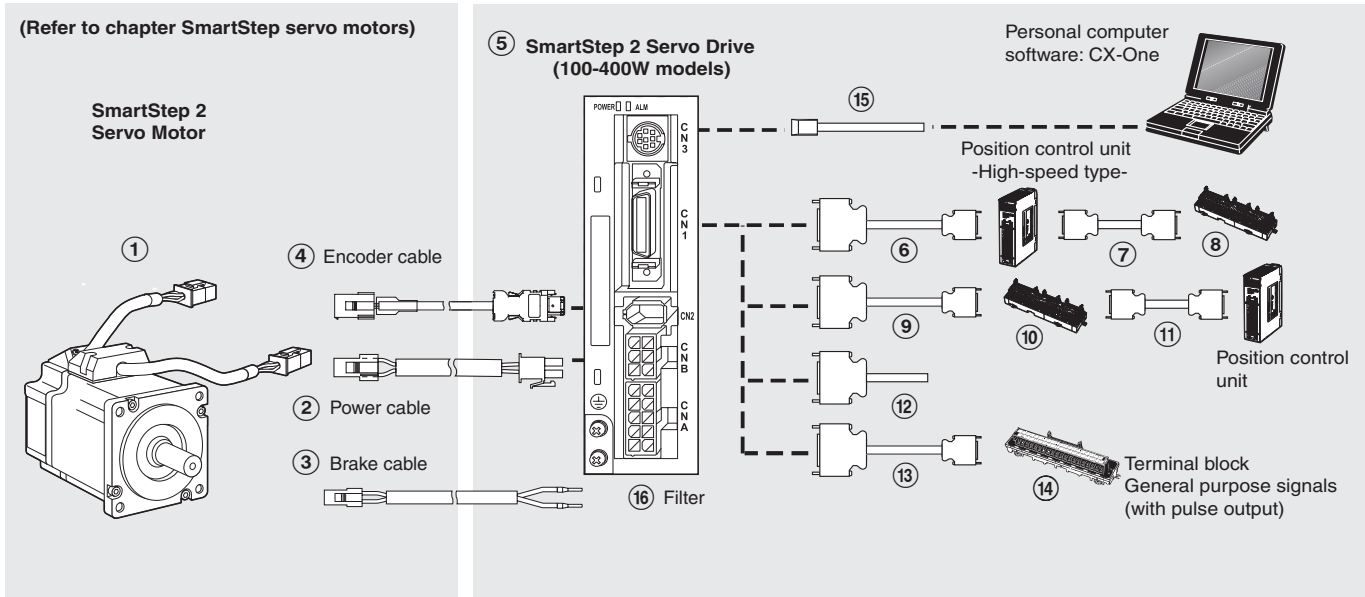

**Note:** The symbols ①②③④⑤... show the recommended sequence to select the components in a SmartStep 2 servo system

**Servo motor**

**Cylindrical servo motors (3,000-r/min)**

Symbol	Specifications				Servo motor model	Compatible servo drives ⑤
	Design		Rated torque	Capacity		
①	Straight shaft with key and tap	Without brake	0.16 Nm	50 W	R88M-G05030H-S2	R7D-BP01H
			0.32 Nm	100 W	R88M-G10030H-S2	R7D-BP02HH
			0.64 Nm	200 W	R88M-G20030H-S2	R7D-BP04H
			1.3 Nm	400 W	R88M-G40030H-S2	R7D-BP04H
	With brake		0.16 Nm	50 W	R88M-G05030H-BS2	R7D-BP01H
			0.32 Nm	100 W	R88M-G10030H-BS2	R7D-BP02HH
			0.64 Nm	200 W	R88M-G20030H-BS2	R7D-BP04H
			1.3 Nm	400 W	R88M-G40030H-BS2	R7D-BP04H

**Flat servo motors (3,000-r/min)**

Symbol	Specifications				Servo motor model	Compatible servo drives ⑤
	Design		Rated torque	Capacity		
①	Straight shaft with key and tap	Without brake	0.32 Nm	100 W	R88M-GP10030H-S2	R7D-BP01H
			0.64 Nm	200 W	R88M-GP20030H-S2	R7D-BP02HH
			1.3 Nm	400 W	R88M-GP40030H-S2	R7D-BP04H
			0.32 Nm	100 W	R88M-GP10030H-BS2	R7D-BP01H
	With brake		0.64 Nm	200 W	R88M-GP20030H-BS2	R7D-BP02HH
			1.3 Nm	400 W	R88M-GP40030H-BS2	R7D-BP04H

**Servo drives**

Symbol	Specifications		SmartStep 2 drive model	Compatible servo motors ①	
				Cylindrical type	Flat type
⑤	200 VAC	100 W	R7D-BP01H	R88M-G05030H-□	-
		200 W	R7D-BP02HH	R88M-G10030H-□	R88M-GP10030H-□
		400 W	R7D-BP04H	R88M-G20030H-□	R88M-GP20030H-□
				R88M-G40030H-□	R88M-GP40030H-□

**Power Supply cables (for CNA)**

Symbol	Specifications	Model	Appearance
⑤	Power Supply Input Cable for Single-Phase Power (connectors attached)	R7A-CLB002S2	

Servo motor cables

Power cables (for CNB)

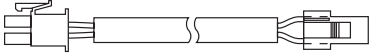
Symbol	Specifications	Model	Appearance	
②	Power cables for SmartStep 2 Servo motors	1.5 m	R7A-CAB001-5SR-E	
		3 m	R7A-CAB003SR-E	
		5 m	R7A-CAB005SR-E	
		10 m	R7A-CAB010SR-E	
		15 m	R7A-CAB015SR-E	
		20 m	R7A-CAB020SR-E	

Brake cables

Symbol	Specifications	Model	Appearance	
③	Brake cables for SmartStep 2 Servo motors	1.5 m	R88A-CAGA001-5BR-E	
		3 m	R88A-CAGA003BR-E	
		5 m	R88A-CAGA005BR-E	
		10 m	R88A-CAGA010BR-E	
		15 m	R88A-CAGA015BR-E	
		20 m	R88A-CAGA020BR-E	

Encoder cables (for CN2)

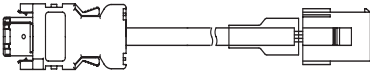
Symbol	Specifications	Model	Appearance	
④	Encoder cables for SmartStep 2 Servo motors	1.5	R88A-CRGB001-5CR-E	
		3 m	R88A-CRGB003CR-E	
		5 m	R88A-CRGB005CR-E	
		10 m	R88A-CRGB010CR-E	
		15 m	R88A-CRGB015CR-E	
		20 m	R88A-CRGB020CR-E	

Note: ②, ④ Flexible and shielded cable  
 ③ Flexible cable

Control cables (for CN1)

Symbol	Description	Connect to	Model	
⑥	Control cable (line-driver output for 1 axis)	Position control unit (high-speed type) CJ1W-NC234 CJ1W-NC434	1 m	XW2Z-100J-G12
			5 m	XW2Z-500J-G12
			10 m	XW2Z-10MJ-G12
	Control cable (open-collector output for 1 axis)	Position control unit (high-speed type) CJ1W-NC214 CJ1W-NC414	1 m	XW2Z-100J-G16
3 m			XW2Z-300J-G16	
Control cable (line-driver output for 2 axis)	Position control unit (high-speed type) CJ1W-NC234 CJ1W-NC434	1 m	XW2Z-100J-G4	
		5 m	XW2Z-500J-G4	
		10 m	XW2Z-10MJ-G4	
Control cable (open-collector output for 2 axis)	Position control unit (high-speed type) CJ1W-NC214 CJ1W-NC414	1 m	XW2Z-100J-G8	
		3 m	XW2Z-300J-G8	
⑦	Terminal block cable for external signals (for input common, forward/reverse run prohibited inputs, emergency stop input, origin proximity input and interrupt input)	Position control units (high-speed type) CJ1W-NC234 CJ1W-NC434 CJ1W-NC214 CJ1W-NC414	0.5 m	XW2Z-C50X
			1 m	XW2Z-100X
			2 m	XW2Z-200X
			3 m	XW2Z-300X
			5 m	XW2Z-500X
			10 m	XW2Z-010X
⑧	Terminal block for external signals (with M3 screw and for pin terminals)		-	XW2B-20G4
	Terminal block ext. signals (with M3.5 screw and for fork/round terminals)		-	XW2B-20G5
	Terminal block ext. signals (with M3 screw and fork/round pin terminals)		-	XW2D-20G6
⑨	Cable from servo relay unit to servo drive	CS1W-NC1□3, CJ1W-NC1□3, C200HW-NC113, CS1W-NC2□3/4□3, CJ1W-NC2□3/4□3, C200HW-NC213/413, CQM1H-PLB21 or CQM1-CPU43-V1	1 m	XW2Z-100J-B29
			2 m	XW2Z-200J-B29
		CJ1M-CPU21/22/23	1 m	XW2Z-100J-B32
			2 m	XW2Z-200J-B32
⑩	Servo relay unit	CS1W-NC1□3, CJ1W-NC1□3 or C200HW-NC113 position control unit	-	XW2B-20J6-1B (1 axis)
			-	XW2B-40J6-2B (2 axes)
		CS1W-NC2□3/4□3, CJ1W-NC2□3/4□3 or C200HW-NC213/413 position control unit CQM1H-PLB21 or CQM1-CPU43-V1 CJ1M-CPU21/22/23	-	XW2B-20J6-3B (1 axis)
			-	XW2B-20J6-8A (1 axis) XW2B-40J6-9A (2 axes)

Symbol	Description	Connect to		Model
⑪	Position control unit connecting cable	CJ1W-NC133	0.5 m	XW2Z-050J-A18
			1 m	XW2Z-100J-A18
		CJ1W-NC233/433	0.5 m	XW2Z-050J-A19
			1 m	XW2Z-100J-A19
		CS1W-NC133	0.5 m	XW2Z-050J-A10
			1 m	XW2Z-100J-A10
		CS1W-NC233/433	0.5 m	XW2Z-050J-A11
			1 m	XW2Z-100J-A11
		CJ1W-NC113	0.5 m	XW2Z-050J-A14
			1 m	XW2Z-100J-A14
		CJ1W-NC213/413	0.5 m	XW2Z-050J-A15
			1 m	XW2Z-100J-A15
		CS1W-NC113	0.5 m	XW2Z-050J-A6
			1 m	XW2Z-100J-A6
		CS1W-NC213/413	0.5 m	XW2Z-050J-A7
			1 m	XW2Z-100J-A7
		C200HW-NC213/413	0.5 m	XW2Z-050J-A33
			1 m	XW2Z-100J-A33
CJ1M-CPU21/22/23	0.5 m	XW2Z-050J-A3		
	1 m	XW2Z-100J-A3		
CQM1H-PLB21	0.5 m	XW2Z-050J-A3		
	1 m	XW2Z-100J-A3		
⑫	General purpose cable	For general purpose controllers	1 m	R7A-CPB001S
			2 m	R7A-CPB002S
⑬	Terminal block cable	For general purpose controllers	1 m	XW2Z-100J-B28
			2 m	XW2Z-200J-B28
⑭	Terminal block ( with M3 screw and for pin terminals)		-	XW2B-34G4
	Terminal block ( with M3.5 screw and for fork/round terminals)		-	XW2B-34G5
	Terminal block ( with M3 screw and fork/round pin terminals)		-	XW2D-34G6

**Cable for CN3**

Symbol	Name	Length	Model
⑮	Personal Computer Monitor Cable	2 m	R88A-CCG002P2

**Filters**

Symbol	Applicable servo drive	Rated current	Rated voltage	Filter model
⑯	R7D-BP01H/ 02HH/ 04H	4 A	1 pH, 230 V	R7A-FIB104-RE

**Connectors**

Specifications	Model
Main Circuit Connector (CNA)	R7A-CNB01P
Servomotor Connector (CNB)	R7A-CNB01A
Control I/O Connector (CN1)	R88A-CNW01C
Encoder Input Connector (CN2)	R88A-CNW01R
Servomotor Connector for Encoder Cable	R88A-CNG02R
Servomotor Connector for Servomotor Power Cable	R88A-CNG01A
Brake Cable Connector	R88A-CNG01B

**External regeneration resistor**

Specification	Model
80 W, 50 Ω	R88A-RR08050S
80 W, 100 Ω	R88A-RR080100S
220 W, 47 Ω	R88A-RR22047S

**External regeneration resistor cable**

Specifications	Model
External Regenerative Resistor Connection Cable, 2 meters	R7A-CLB002RG

**Parameter unit & computer software**

Specifications	Model
Parameter copy unit (with cable)	R88A-PR02G
Configuration and monitoring software tool for servo drives and inverters. (CX-drive version 1.8 or higher)	CX-drive



SmartStep2 Servo Drive Configuration (750W)

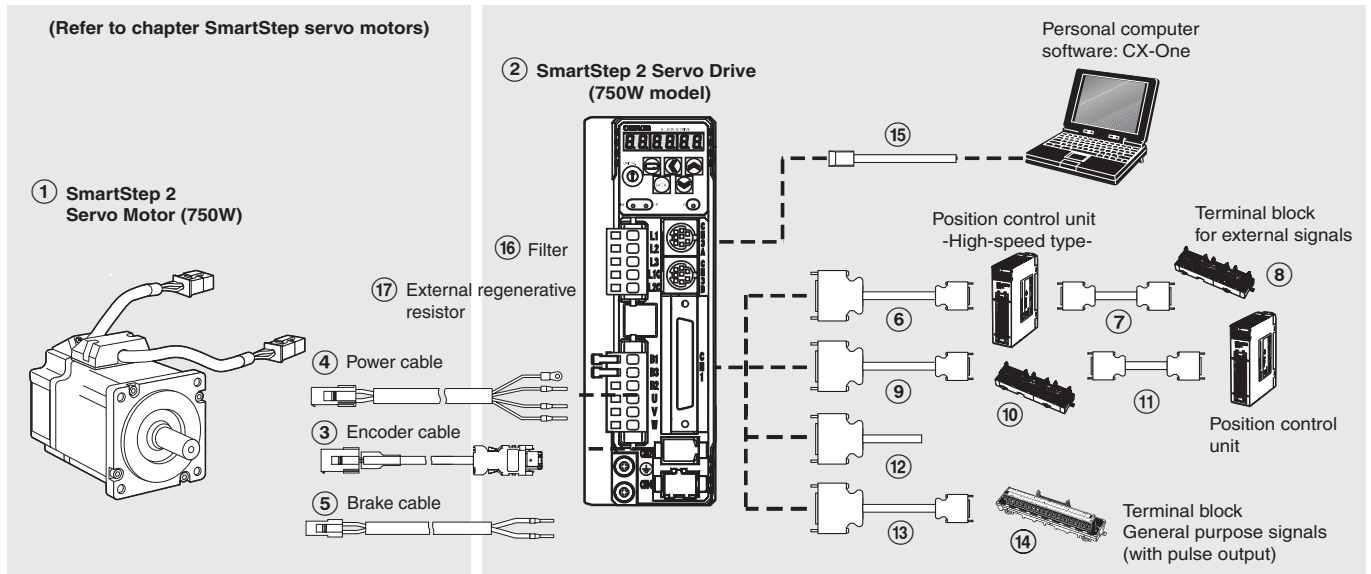

Note: The symbols ①②③④⑤... show the recommended sequence to select the components in a SmartStep 2 servo system.

Servo drives

Symbol	Specifications	Servo drive model	① Compatible rotary servo motors
②	1 phase 200 VAC 750 W	R88D-GP08H	Cylindric type R88M-G75030H-□

Encoder Cables

Symbol	Specifications	Model	Appearance
③	Encoder cable R88M-G75030H-□	1.5 m R88A-CRGB001-5CR-E	
		3 m R88A-CRGB003CR-E	
		5 m R88A-CRGB005CR-E	
		10 m R88A-CRGB010CR-E	
		15 m R88A-CRGB015CR-E	
		20 m R88A-CRGB020CR-E	

Power cables

Symbol	Specifications	Model	Appearance
④	For 750W servomotors without brake R88M-G75030H-S2  For servomotors with brake, a separate cable (R88A-CAGA□BR-E) is needed	1.5 m R88A-CAGA001-5SR-E	
		3 m R88A-CAGA003SR-E	
		5 m R88A-CAGA005SR-E	
		10 m R88A-CAGA010SR-E	
		15 m R88A-CAGA015SR-E	
		20 m R88A-CAGA020SR-E	

Brake cable

Symbol	Specifications	Model	Appearance
⑤	Brake cable only. For R88M-G75030H-BS2 servomotors.	1.5 m R88A-CAGA001-5BR-E	
		3 m R88A-CAGA003BR-E	
		5 m R88A-CAGA005BR-E	
		10 m R88A-CAGA010BR-E	
		15 m R88A-CAGA015BR-E	
		20 m R88A-CAGA020BR-E	

Control cables (for CN1)

Symbol	Description	Connect to	Model
⑥	Control cable (line-driver output for 1 axis)	Position control units (high-speed type) CJ1W-NC234	1 m XW2Z-100J-G9
		CJ1W-NC434	5 m XW2Z-500J-G9
		CJ1W-NC434	10 m XW2Z-10MJ-G9
	Control cable (open-collector output for 1 axis)	Position control units (high-speed type) CJ1W-NC214	1 m XW2Z-100J-G13
		CJ1W-NC414	3 m XW2Z-300J-G13
	Control cable (line-driver output for 2 axis)	Position control units (high-speed type) CJ1W-NC234	1 m XW2Z-100J-G1
		CJ1W-NC434	5 m XW2Z-500J-G1
		CJ1W-NC434	10 m XW2Z-10MJ-G1
	Control cable (open-collector output for 2 axis)	Position control units (high-speed type) CJ1W-NC214	1 m XW2Z-100J-G5
		CJ1W-NC414	3 m XW2Z-300J-G5

Symbol	Description	Connect to	Model	
⑦	Terminal block cable for external signals (for input common, forward/reverse run prohibited inputs, emergency stop input, origin proximity input and interrupt input)	Position control units (high-speed type) CJ1W-NC234 CJ1W-NC434 CJ1W-NC214 CJ1W-NC414	0.5 m	XW2Z-C50X
			1 m	XW2Z-100X
			2 m	XW2Z-200X
			3 m	XW2Z-300X
			5 m	XW2Z-500X
			10 m	XW2Z-010X
⑧	Terminal block for external signals (M3 screw, pin terminals)		-	XW2B-20G4
	Terminal block ext. signals(M3.5 screw, fork/round terminals)		-	XW2B-20G5
	Terminal block ext. signals(M3 screw, fork/round terminals)		-	XW2D-20G6
⑨	Cable from servo relay unit to servo drive	CS1W-NC1□3, CJ1W-NC1□3, C200HW-NC113/213/413, CS1W-NC2□3/4□3, CJ1W-NC2□3/4□3 or CQM1H-PLB21	1 m	XW2Z-100J-B25
			2 m	XW2Z-200J-B25
		CJ1M-CPU21/22/23	1 m	XW2Z-100J-B31
			2 m	XW2Z-200J-B31
⑩	Servo relay unit	CS1W-NC1□3, CJ1W-NC1□3 or C200HW-NC113 position control unit	-	XW2B-20J6-1B (1 axis)
			-	XW2B-40J6-2B (2 axes)
		CS1W-NC2□3/4□3, CJ1W-NC2□3/4□3 or C200HW-NC213/413 position control unit	-	XW2B-20J6-3B (1 axis)
			-	XW2B-20J6-8A (1 axis)
		CJ1M-CPU21/22/23	-	XW2B-40J6-9A (2 axes)
⑪	Position control unit connecting cable	CQM1H-PLB21	0.5 m	XW2Z-050J-A3
			1 m	XW2Z-100J-A3
		CS1W-NC113 or C200HW-NC113	0.5 m	XW2Z-050J-A6
			1 m	XW2Z-100J-A6
		CS1W-NC213/413 or C200HW-NC213/413	0.5 m	XW2Z-050J-A7
			1 m	XW2Z-100J-A7
		CS1W-NC133	0.5 m	XW2Z-050J-A10
			1 m	XW2Z-100J-A10
		CS1W-NC233/433	0.5 m	XW2Z-050J-A11
			1 m	XW2Z-100J-A11
		CJ1W-NC113	0.5 m	XW2Z-050J-A14
			1 m	XW2Z-100J-A14
		CJ1W-NC213/413	0.5 m	XW2Z-050J-A15
			1 m	XW2Z-100J-A15
		CJ1W-NC133	0.5 m	XW2Z-050J-A18
			1 m	XW2Z-100J-A18
CJ1W-NC233/433	0.5 m	XW2Z-050J-A19		
	1 m	XW2Z-100J-A19		
CJ1M-CPU21/22/23	0.5 m	XW2Z-050J-A33		
	1 m	XW2Z-100J-A33		
⑫	General purpose cable	For general purpose controllers	1 m	R88A-CPG001S
			2 m	R88A-CPG002S
⑬	Terminal block cable	For general purpose controllers	1 m	XW2Z-100J-B24
			2 m	XW2Z-200J-B24
⑭	Terminal block (M3 screw and for pin terminals)		-	XW2B-50G4
	Terminal block (M3.5 screw and for fork/round terminals)		-	XW2B-50G5
	Terminal block (M3 screw and for fork/round terminals)		-	XW2D-50G6

**Computer cable (for CN3)**

Symbol	Name	Model
⑮	Computer cable RS232	2 m R88A-CCG002P2

**Filter**

Symbol	Applicable servodrive	Filter model	Rated current	Leakage current	Rated voltage
⑯	R88D-GP08H	R88A-FIK107-RE	6.6 A	3.5 mA	250 VAC single-phase

**External regenerative resistor**

Symbol	Regenerative resistor unit model	Specifications
⑰	R88A-RR08050S	50 Ω, 80 W
	R88A-RR080100S	100 Ω, 80 W
	R88A-RR22047S	47 Ω, 220 W
	R88A-RR50020S	20 Ω, 500 W

**Connectors**

Specifications	Model
I/O connector kit -50 pins- (for CN1)	R88A-CNU11C
Power cable connector (motor side)	R88A-CNG01A
Encoder connector (Servo drive side CN2)	R88A-CNW01R
Incremental encoder cable connector (motor side)	R88A-CNG02R

**Computer software**

Specifications	Model
Configuration and monitoring software tool for servo drives and inverters (CX-drive version 1.91 or higher).	CX-Drive

**OMRON EUROPE B.V.** Wegalaan 67-69, NL-2132 JD, Hoofddorp, The Netherlands. Tel: +31 (0) 23 568 13 00 Fax: +31 (0) 23 568 13 88 [www.industrial.omron.eu](http://www.industrial.omron.eu)

---

**Austria**

Tel: +43 (0) 2236 377 800  
[www.industrial.omron.at](http://www.industrial.omron.at)

**Belgium**

Tel: +32 (0) 2 466 24 80  
[www.industrial.omron.be](http://www.industrial.omron.be)

**Czech Republic**

Tel: +420 234 602 602  
[www.industrial.omron.cz](http://www.industrial.omron.cz)

**Denmark**

Tel: +45 43 44 00 11  
[www.industrial.omron.dk](http://www.industrial.omron.dk)

**Finland**

Tel: +358 (0) 207 464 200  
[www.industrial.omron.fi](http://www.industrial.omron.fi)

**France**

Tel: +33 (0) 1 56 63 70 00  
[www.industrial.omron.fr](http://www.industrial.omron.fr)

**Germany**

Tel: +49 (0) 2173 680 00  
[www.industrial.omron.de](http://www.industrial.omron.de)

**Hungary**

Tel: +36 1 399 30 50  
[www.industrial.omron.hu](http://www.industrial.omron.hu)

**Italy**

Tel: +39 02 326 81  
[www.industrial.omron.it](http://www.industrial.omron.it)

**Netherlands**

Tel: +31 (0) 23 568 11 00  
[www.industrial.omron.nl](http://www.industrial.omron.nl)

**Norway**

Tel: +47 (0) 22 65 75 00  
[www.industrial.omron.no](http://www.industrial.omron.no)

**Poland**

Tel: +48 (0) 22 645 78 60  
[www.industrial.omron.pl](http://www.industrial.omron.pl)

**Portugal**

Tel: +351 21 942 94 00  
[www.industrial.omron.pt](http://www.industrial.omron.pt)

**Russia**

Tel: +7 495 648 94 50  
[www.industrial.omron.ru](http://www.industrial.omron.ru)

**South-Africa**

Tel: +27 (0)11 579 2600  
[www.industrial.omron.co.za](http://www.industrial.omron.co.za)

**Spain**

Tel: +34 913 777 900  
[www.industrial.omron.es](http://www.industrial.omron.es)

**Sweden**

Tel: +46 (0) 8 632 35 00  
[www.industrial.omron.se](http://www.industrial.omron.se)

**Switzerland**

Tel: +41 (0) 41 748 13 13  
[www.industrial.omron.ch](http://www.industrial.omron.ch)

**Turkey**

Tel: +90 216 474 00 40  
[www.industrial.omron.com.tr](http://www.industrial.omron.com.tr)

**United Kingdom**

Tel: +44 (0) 870 752 08 61  
[www.industrial.omron.co.uk](http://www.industrial.omron.co.uk)

**More Omron representatives**  
[www.industrial.omron.eu](http://www.industrial.omron.eu)

**Automation Systems**

- Programmable logic controllers (PLC) • Human machine interfaces (HMI) • Remote I/O
- Industrial PC's • Software

**Motion & Drives**

- Motion controllers • Servo systems • Inverters

**Control Components**

- Temperature controllers • Power supplies • Timers • Counters • Programmable relays
- Digital panel indicators • Electromechanical relays • Monitoring products • Solid-state relays
- Limit switches • Pushbutton switches • Low voltage switch gear

**Sensing & Safety**

- Photoelectric sensors • Inductive sensors • Capacitive & pressure sensors
- Cable connectors • Displacement & width-measuring sensors • Vision systems
- Safety networks • Safety sensors • Safety units/relay units • Safety door/guard lock switches